



Review Article

Advances in solar absorption cooling systems: An overview

S. C. KAUSHIK¹, Abhishek VERMA¹, S. K. TYAGI^{1,*}

¹Department of Energy Science and Engineering, Indian Institute of Technology Delhi, Hauz Khas, New Delhi, 110016, India

ARTICLE INFO

Article history

Received: 10 May 2022

Revised: 06 October 2022

Accepted: 12 October 2022

Keywords:

Absorption Refrigeration;
Alternative Refrigeration; Low-
Grade Thermal Energy; Solar
Collectors; Solar Energy

ABSTRACT

The need for refrigeration and air conditioning plays a crucial role in energy consumption. It is one of the important aspects which plays a crucial role in the food, human comfort, and energy problems of any country. Rapid consumption of energy and fossil fuels depletion results in the onset of energy crises thus, the research on absorption refrigeration systems has been widely promoted because the input energy supply for the systems can be a low-grade heat available from solar, geothermal, and/or waste heat from Industries. Solar refrigeration and air conditioning is an attractive and promising applications of solar energy because the cooling demand and the availability of solar energy are in phase and solar cooling can be made cost-effective. The present work includes the solar energy option and the potential for cooling with various range of parameters such as availability of solar radiation, environmental effects, types of collectors, types of solar cooling systems in general, and closed/open/continuous/multistage/hybrid and advanced absorption refrigeration cycles in particular. A literature survey has been carried out for possible improvements in the performance of solar absorption cooling systems and different solar collection and storage options. The most suitable solar cooling option viz. absorption refrigeration with the solar operation, historical developments, and commercial products. Advanced absorption cycles and novel cooling systems have also been presented and discussed.

Cite this article as: Kaushik SC, Verma A, Tyagi SK. Advances in solar absorption cooling systems: An overview. J Ther Eng 2024;10(4):1–24.

INTRODUCTION

The conventional refrigeration and space conditioning devices utilize fossil fuels and/or electrical energy for their operation. The ease of use of oil and natural gas has become extensively scarcer, and the production of coal is also not so promising on a worldwide basis. In addition to supplying energy, fossil fuels are also being used extensively as fuel stock material for the manufacture of various chemicals.

With the onset of energy crises heavy energy consumption fossil fuels depletion, the demanding research for the use of alternative available energy sources has become an essential part. With a very high potential among renewable sources, solar energy is most promising since it is an inexhaustible, abundantly available global energy source with almost no pollution or other health hazards associated. The average power intercepted from the Sun by the Earth is around 1.3×10^{11} MW, which is many orders of magnitude greater than

*Corresponding author.

*E-mail address: abhishek.ret@gmail.com

This paper was recommended for publication in revised form by Regional Editor Emre Alpman



the present Earth energy consumption rate. Consequently, solar energy can meet all the world's current and future energy requirements continually.

Solar Energy Option

Solar energy in the form of heat can be used for a variety of applications. Energy Research and development programs in developing countries are oriented toward low-temperature applications like water heating/distillation, crop drying, greenhouses, biogas production, and small hydropower systems while in developed countries, the main emphasis is on the high technology applications which utilize solar energy viz. space heating and/or cooling, solar refrigeration, and solar electricity production. However, there is a sharp transition in solar energy utilization everywhere in the world and the use of solar energy for a variety of applications is the most attractive one because it is a freely available, abundant, and infinite source of energy [1]. Considerable attention is being devoted to the collection and storage of energy from the Sun on account of solar radiation being diluted and intermittent. Long-term high-temperature storage devices require Thermochemical storage and, in this area, considerable research and development work is being done. The low-temperature production and short-term storage of solar energy are also being considered.

One of the key contributors to global warming is conventional energy use in refrigeration. Particularly in hot and sunny locations, solar cooling systems are becoming more compact, more affordable, and possible alternative technologies [2]. Solar cooling in particular is the most attractive in view of the fact that the demand for cooling is in phase with the availability of solar energy. Solar cooling can be most directly useful to food preservation as well as air conditioning. However, the major drawback of solar refrigeration is the intermittent solar power source. Food preservation requires extreme reliability of the system as unscheduled failure may cause total loss of the storage goods. This is not the case for air conditioning systems as the load is also reduced by a few solar gains received by the space to be cooled. As regarding solar power production, conventionally there are two methods used to convert radiant energy from Sun into the useful electrical energy (i) Photovoltaic conversion route which converts the radiation of the Sun directly into electrical energy, and (ii) thermal conversion route which first converts Sun's radiation into heat, which can further be transformed into mechanical and then the electrical energy. The efficiencies associated with these conversion processes (that have been achieved) indicate that the thermal conversion route is more efficient while the Photovoltaic conversion is cleaner and encompasses static parts, hence less maintenance problems.

It is thus evident that both direct and indirect utilization of energy from the Sun offers a great promise for the future of mankind, especially for the developing nations that seem to have a good share of sunshine. However, the merits of

solar energy development must be considered according to the following points:

- i) the existence of technology or its development to transform solar energy into useful forms
- ii) the economics of its transformation
- iii) the effect of development on the environment and the efficiencies of transformation and utilization in view of the laws of thermodynamics.

Any analysis of solar energy development will be incomplete and inaccurate without looking at it from the thermodynamic viewpoint. Established first and second laws of thermodynamics play a significant role in the energetics of the universe not only from the viewpoint of physics but from the economic point as well. In solar energy development, we come across many possibilities regarding the collection, conversion, and storage of the usage of solar energy. In all these phases of development, the overall system efficiency will be given by the product of the individual efficiencies i.e.

$$\eta_{\text{system}} = \eta_{\text{collection}} \times \eta_{\text{conversion}} \times \eta_{\text{storage}} \quad (1)$$

The problem, therefore, is optimization that requires system cost, system efficiency, or system yield extremization. Naturally, the efficiencies of these processes have to be viewed and those with higher efficiencies might be more attractive. Another important aspect is the economic consideration, which may also be looked at in a way similar to the analysis based on the laws of thermodynamics.

Potential for Solar Cooling

Cooling from the sun is one of the most vital aspects of solar thermal utilization and is quite similar to many other solar thermal utilization systems.

Solar cooling is more striking due to the following aspects:

- i) The cooling demand is mostly the greatest at times of maximum availability of solar radiation, and
- ii) The cooling demand is much needed in hotter regions as compared to in colder climates

In tropical regions, solar energy-powered cold storage, refrigeration, and space conditioning systems are in high demand. Due to the resource (power) absenteeism in rural areas of the country, there is a major shortage of cold storage facilities, resulting in the waste of thousands of tonnes of perishable foodstuffs such as vegetables, fruits, fish, and similar other food materials each year. Even minimal refrigeration facilities to preserve important medicines are not available in rural health care centers, resulting in lifesaving medical care not being supplied during an emergency. Similarly, human comfort space cooling services cannot be given even during extremely hot and cold seasons due to a lack of electrical energy. Solar cooling systems can provide these facilities since solar energy is freely available all over the world. But solar energy is unlikely to come across a huge fraction of the world power demand, its contribution

may be limited to specific areas lying between the latitudes $\pm 40^\circ$ where the solar energy is of sufficient intensity and infrequent cloud cover gives good reliability. Solar refrigeration systems will reduce food wastage and improve food distribution thus increasing productivity and natural wealth. In a country like India, food production centers are usually situated in areas where electric supply for running large refrigeration units is not available. Therefore, a solar cooling system that does not depend completely on electricity for its operation will be the most ideal one under such circumstances. The food production centers in the rural and coastal regions happen to be the most suitable for harnessing solar energy over vast open areas. Aliane et al. [3] reviewed research on solar absorption systems. The experimental studies that were specifically chosen for the literature review are based on. This paper focuses on the operational characteristics required to run an absorption chiller using solar energy. In order to achieve the economic viability of heating and cooling systems. Corrada et al. [4] carried out a theoretical study on improving solar collector tilt angle to enhance energy harvesting in solar cooling systems. For a solar cooling and heating installation, the flat plate collectors seem to perform well for smaller capacity. For a high-efficiency medium-temperature solar cooling system, Rossetti et al. [5] conducted a theoretical study on the performance analysis of a medium-temperature solar cooling plant. To evaluate the effectiveness and likelihood of establishing a pilot plant, a numerical model in TRNSYS has been developed.

Almasri et al. [6] explored several solar sorption cooling systems, including adsorption, absorption, and evaporative cooling systems. The analysis demonstrates that the solar absorption system is more effective than competing technologies, and as a result, it is frequently employed for cooling purposes in a variety of applications. Phase change materials and nanofluids in solar sorption systems were also presented as a significant area that requires further study. Solar-powered cooling systems can help to enhance the quality of the air within buildings. LiBr/H₂O and single-effect absorption chillers are the most common working fluids in solar-powered cooling systems. When compared to traditional air conditioning systems, solar-powered air conditioners can help save 40 to 50% of energy and decrease the consumption of fossil fuels. Flat-plate or evacuated tube solar collectors can be utilized with gas-fired absorption chillers, but only when they are run in air-cooling mode will their efficiency be adequate. They are more suited for use in hot, arid areas that experience a water shortage [7].

This work presents a comprehensive review of the basics and advances in technologies mainly in the field of absorption refrigeration systems, along with their solar operation and energy conservation. It includes the basics of solar energy utilization for various refrigeration cycles in general and absorption systems in particular. The state of art review is presented on the solar operation of absorption cooling systems, which includes intermittent/ open cycle/

closed cycle for its continuous operation for different applications and locations. Further, hybrid absorption systems have been presented for multigeneration purposes in different modes. The case studies and commercially available solar-operated absorption cooling systems have been presented. The modifications in the basic cycle structures such as the multi-effect absorption systems, combined absorption-resorption cycles, ejector-absorption cycles, etc., along with the hybridization with other refrigeration technologies with various solar collection units have been presented in detail. All the aspects discussed above will provide an opportunity for the readers, researchers, and scientists to look at the current scenario and advancements in the field of solar operated absorption cooling systems, which may help in the development and investigations of cost-effective cooling systems.

TYPES OF SOLAR COOLING SYSTEMS

There is abundant scope for the utilization of energy from the sun, for cooling applications as the availability of the energy is in phase with the demand for cooling which is maximum in summer and lesser in winter. Moreover, the solar collector efficiency is relatively high in summer because of the high ambient air temperature as compared to that in winter. The development of solar cooling devices has been dwarfed because of the availability of relatively low temperatures from solar collectors. However, with modern collectors, there is new hope for solar cooling systems. Solar cooling can be achieved by many alternative methods as shown in Table 1. Solar cooling systems that are both active and passive and are available for refrigeration and space conditioning have been proposed and discussed in the literature. Passive solar space conditioning systems are based on evaporative cooling and radiative cooling developments and can be integrated with the building structure itself. Active solar cooling systems, most commonly used, are based on vapour refrigeration systems which include both vapour compression refrigeration (normally driven by electric power) and vapour absorption refrigeration (normally using low-quality heat like solar energy). For hot and humid climates another type of cooling based on the adsorption process or dehumidification is preferred. The conventional refrigeration and air conditioning machines run on electrical energy and/or fossil fuels indirectly for their operation. Thus, solar cooling is one of the most imperative aspects of solar energy utilization. A solar cooling system necessarily needs solar collection and storage units along with the cooling device for its continuous solar operation. Solar operation of a vapour compression (V-C) refrigeration cycle is achieved by two methods giving new independent propositions for cooling. Solar energy can be converted into mechanical energy and the compressor of the V-C refrigeration system can be driven by this energy. This is known as Rankine cycle cooling. There is another version based on the inverse Rankine cycle for producing cooling using solar

Table 1. Active solar cooling options

Vapour Compression Refrigeration	Vapour Absorption Cooling	Vapour Adsorption Cooling	Non-conventional Cooling
1. Conventional electricity operated V-C systems	1. Closed cycle systems	1. Open cycle systems	1. Solar thermoelectric refrigeration
2. Solar thermal conservation-based V-C cooling	a. Continuous absorption solar refrigeration system	a. Solid adsorption	2. Gas cycle solar refrigeration
3. Photovoltaic conversion-based V-C refrigeration	b. Intermittent absorption solar refrigeration system	b. Solid adsorption	3. Stirling gas cycle-based solar cooling
4. Rankine cycle solar cooling (Heat engine coupled V-C cycle)	2. Open cycle absorption air-conditioning	2. Closed cycle adsorption systems	4. Metal-hydride compressor refrigeration
5. Jet ejector compression solar refrigeration cycle	3. Multistage absorption cooling system	3. Hybrid cooling systems	5. Thermo-acoustic solar cooling
	4. Advanced absorption cycles		

energy. In this cooling process, solar energy may be converted into mechanical energy with which the refrigerant air is compressed. Subsequently, it is cooled to remove heat from it. The cold air is then expanded through a turbine where work may be extracted. The cold exhaust air is discharged into the air conditioning space.

The Stirling cycle heat engine can also be utilized for solar cooling when an engine transmits mechanical power to any form of cooling unit or when the Stirling engine and cooling system are integrated. The first approach allows for greater engine design flexibility and a broader selection of cooling systems, whereas the second approach is based on the use of a single driving mechanism for the engine and cooling units, as well as the use of the same working fluid in the cooling and power cycles. The system is hermetic and has efficiency comparable to the Rankine cycle cooling system. In the steam Jet compression version of the cooling cycle, the mechanical compressor is replaced by a convergent-divergent nozzle known as a Jet pump. The primary fluid which receives heat as input from the solar collectors is expanded within the jet pump thereby affecting the compression of the refrigerant, and suction is caused in the evaporator where cooling occurs. Thus, a jet ejector can be used to reduce the pressure over a liquid refrigerant. This causes evaporation from and hence cooling of the liquid. Refrigerant cooled in this manner is circulated through a heat exchanger to affect the desired space cooling.

Generally, with thermodynamic machines, it is advisable to have as few energy conversions as may be possible. Thus, a more direct solar conversion system may be preferable e.g., the absorption refrigeration system with two conversions - radiation to heat and heat to cooling may have some advantage over the engine cycle with three conversions - radiation to heat, heat to work, and work to cool. However, with a vapour absorption system, the refrigeration cycle requires significantly more heat energy to generate a given refrigerating effect than the vapour compression

cycle. The energy input to the former, on the other hand, is mostly in the form of heat, whereas the latter is in the form of work. Heat and work are not comparable kinds of energy, according to the second law of thermodynamics. Heat is low-grade energy because only a part of it is available while work is high-grade energy because all of it is available. Hence no fair comparison of these two systems can be made on the basis of COP (defined as refrigerating effect/energy supplied). Thermodynamically, the V-A cycle (as shown in Figure 1(b)) is identical to a V-C cycle (as shown in Figure 1(a)) in which the compressor is replaced by an absorber and generated assembly. In each mode of operation (cooling or heating), the driving energy is supplied to the generated from a solar collector.

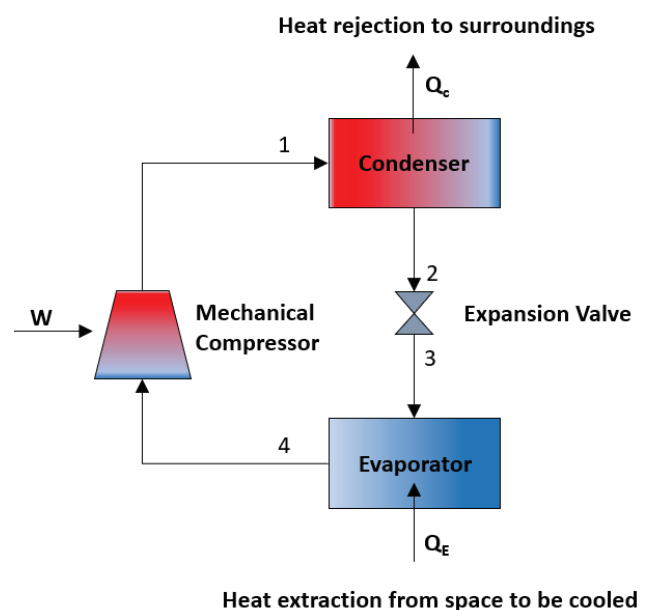
**Figure 1(a).** Vapour compression cycle.

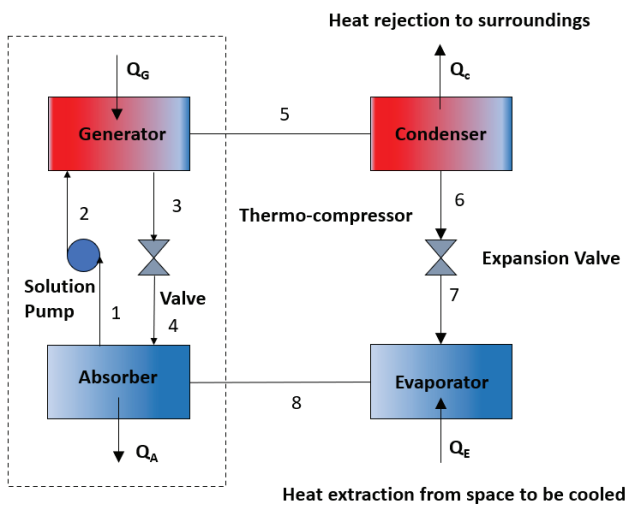

Figure 1(b). Vapour absorption cycle.

Solar energy can also be used to produce cooling by using closed or open cycle absorption cooling systems and/or Absorption-Dehumidification cycles based on solar regeneration of sorbents and liquid desiccants. In V-A solar cooling system, a solution of refrigerant and absorbent is utilized to circulate in the generator-absorber assembly to replace the compressor with a thermo-compressor, and the hot water is used to supply into the generator. The refrigeration effect is produced in the evaporator while the heat is rejected from the absorber and the condenser. The COP of absorption systems is rather low because input energy is heat rather than work. Absorption systems being most suitable for solar cooling are considered in this report in detail.

The adsorption cooling process is similar to the absorption systems except with the difference that the refrigerant is adsorbed onto the surface of the adsorbing material rather than being taken into a chemical solution. The refrigerant is then driven out by heating which is obtained by utilizing the solar energy in the system. The liberated refrigerant vapour is then condensed and throttled to produce the refrigerating effect. The refrigerant is then re-adsorbed into the carrier material to have a closed cycle. Adsorption refrigeration systems are more suitable for lesser hot water temperatures as the requirement is less to generate the refrigerant from the surface of the bed and it is more efficient than the absorption process since the energy supplied to the compressor is of much higher thermodynamic quality than the heat supplied for driving the absorption process. The absorption process operates well with low-grade heat when it is abundantly available like solar energy [8].

Solar Operation of Absorption Cooling Systems

Absorption cooling is one of the oldest cooling processes known in literature. It has long been realized that absorption refrigeration machines could be employed to produce cooling from solar energy [9]. In an absorption

system, to achieve the cooling process, it is essential to produce a means of removing the refrigerant vapour as fast as it is formed. In this case, the evaporator is connected to another vessel containing a substance capable of absorbing the vapour. The substance used to absorb the refrigerant is known as the absorbent. The next stage is the release of the refrigerant at a convenient pressure for its subsequent liquefaction or condensation in a condenser. This is accomplished by pumping the solution to a higher pressure. The solution enters the generator (where heat is supplied to the refrigerant-absorbent solution) and the refrigerant is driven off from the solution as a vapour. The absorbent solution after releasing refrigerant vapour is returned to the absorber. The refrigerant-absorbent mixture is thus thermally compressed without using the input shaft work as demanded by a vapour compression system [10,11]. The use of solar heat for absorption cooling systems has certain limitations as compared to fuel-fired systems (viz. intermittency, low energy concentration, difficulty in control, etc.), and thus solar energy-driven cooling system has to be specifically designed to meet the characteristics of the solar collector. As solar collection efficiency decreases with increasing solar collection temperature, a solar-powered cooling system could never be more efficient than a fuel-powered device, and thus we have an extent of limits that could not be outstripped in solar-powered cooling systems. A solar-powered cooling device is thus identical to any other heat-powered cooling system, except for the additional constraints imposed by the solar as a heat source. The thermodynamic considerations for solar operation of cooling systems yield two key pieces of evidence [12]:

- (i) The quantity of heat provided from the source at the hot end would always be greater than the amount of cooling produced since some of it will be rejected to the sink.
- (ii) In an ideal absorption system, the temperature lift ($T_G - T_A$) is roughly equal to the temperature depression ($T_C - T_E$). Despite the fact that in true absorption systems, depression is always lesser than the lift.

This evidence applies to SE absorption systems while multiple stage systems could show distinct outcomes, i.e., high COP can be acquired at the cost of significantly increased generator temperature. The first statement specifies the minimum amount of heat provided to the collector for a particular refrigerating effect, whilst the second specifies the working temperature of the generator and hence the collector. To study the cost-effectiveness of solar absorption cooling systems, it is necessary to know the daily cooling COP and hence the cooling produced during sunshine hours. When heat input in the generator of the absorption cycle is taken from a solar collector, the available operating generator temperature imposes restrictions on the thermodynamic processes involved in an absorption system. If the input heat is time-dependent, the output of the absorption system will also be time-dependent. Furthermore, the quantity of generated refrigerant is proportional to the amount of heat supplied

to the generator, that is coming from the solar collector, and thus to the amount of solar insolation. This feature has further prompted the use of novel solar collectors to supply high-temperature input heat into the generator of absorption refrigeration systems. The enhanced absorption cycle, which requires a high-temperature heat source, may be successfully operated with the latest developments in high efficiency and high-temperature solar collectors. Solar collector-reflector systems have also been used to supply heat for vapour absorption systems.

SOLAR ABSORPTION COOLING SYSTEMS: STATE OF ART

On the basis of the process of the cycle, there are two kinds of absorption cooling systems - Continuous closed configuration cycle absorption system and intermittent configuration cycle absorption system. The literature review for various configurations and operating parameters for absorption refrigeration systems is presented in Table 2.

Intermittent absorption refrigeration systems

As shown schematically in Figure 2, an intermittent configuration system switches between two modes. The refrigerant is allowed to evaporate in the evaporator during the cooling phase, extracting heat from the solid/liquid or gas to be cooled. The absorber absorbs the refrigerant vapour. Water or air removes the heat of absorption. The regeneration mode is the alternate mode in which the evaporator or condenser and the absorber or generator swap functions. The generator receives heat in order to make refrigerant vapour. The vapour is condensed in the condenser by water or air cooling. The intermittent configuration of cooling operation consists of two phases: regeneration and refrigeration. The former is refrigerant vapour generation by providing heat to the solution of the working fluid, followed by refrigerant vapour condensation. However, refrigeration occurs when the liquid refrigerant vaporizes by absorbing heat from the space to be cooled, and the low-pressure refrigerant vapour generated is reabsorbed by the absorbent in the absorber. Thus,

energy is stored in the form of the amount of separated refrigerant and absorbent masses.

Open configuration absorption solar cooling system

Another possible solar cooling technology is based on the absorption process with an open layout. The open cycle system was proposed and investigated with solar heat as input thermal energy for regenerating the absorbent by Collier in 1979 using water as a refrigerant and lithium chloride as an absorbent [13].

With the combination of the process and heat transfer loops, an open configuration absorption refrigeration system (as shown in Figure 3) removes the interface heat exchangers of the closed configuration cycle. Thus, heat and mass flow to and from the system in an open configuration absorption cycle. The primary distinction between an open configuration and a closed configuration absorption system is that there is no condenser in the former configuration. In principle, this has been swapped by infinite heat and mass reservoirs, and the absorption process modifies the composition of the matter flowing. Studies on these systems are still at the research and laboratory development stage. These systems have the advantage of direct utilization of solar energy for the regeneration process.

Continuous absorption refrigeration systems

Said et al. [14], offered novel ideas for solar-powered absorption systems with aqua-ammonia as the working pair that can operate 24 hours a day as shown in Figure 4. The authors offered two designs: one that operates continuously and one that operates intermittently. The continuous operation system stores cold water, refrigerant, and heat, whereas the intermittent operation system only stores cold water. These were required to provide continuous cooling (during the day and night). The maximum COP was achieved by the heat storage system, although it required adequate insulation. For the weather conditions in Dhahran, Saudi Arabia, the system with refrigerant storage for the continuous operation was best the optimum solution. The bulk of cooling systems employs water cooling towers, which have concerns with water consumption, resulting in greater expenses, which are rigorously monitored.

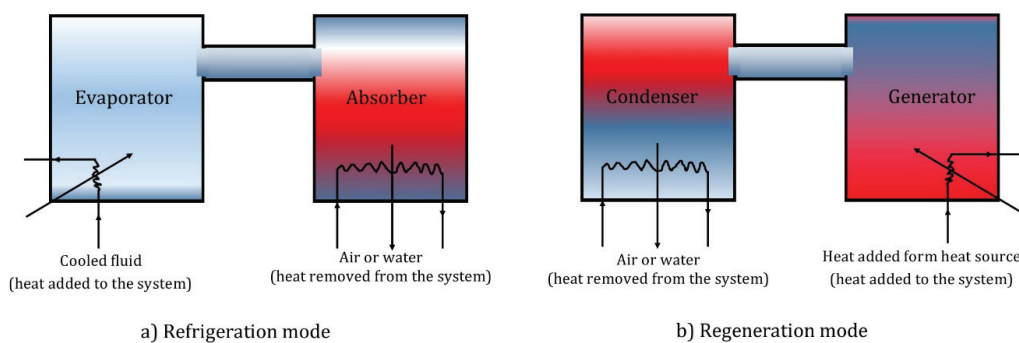

Figure 2. An intermittent absorption cooling system.

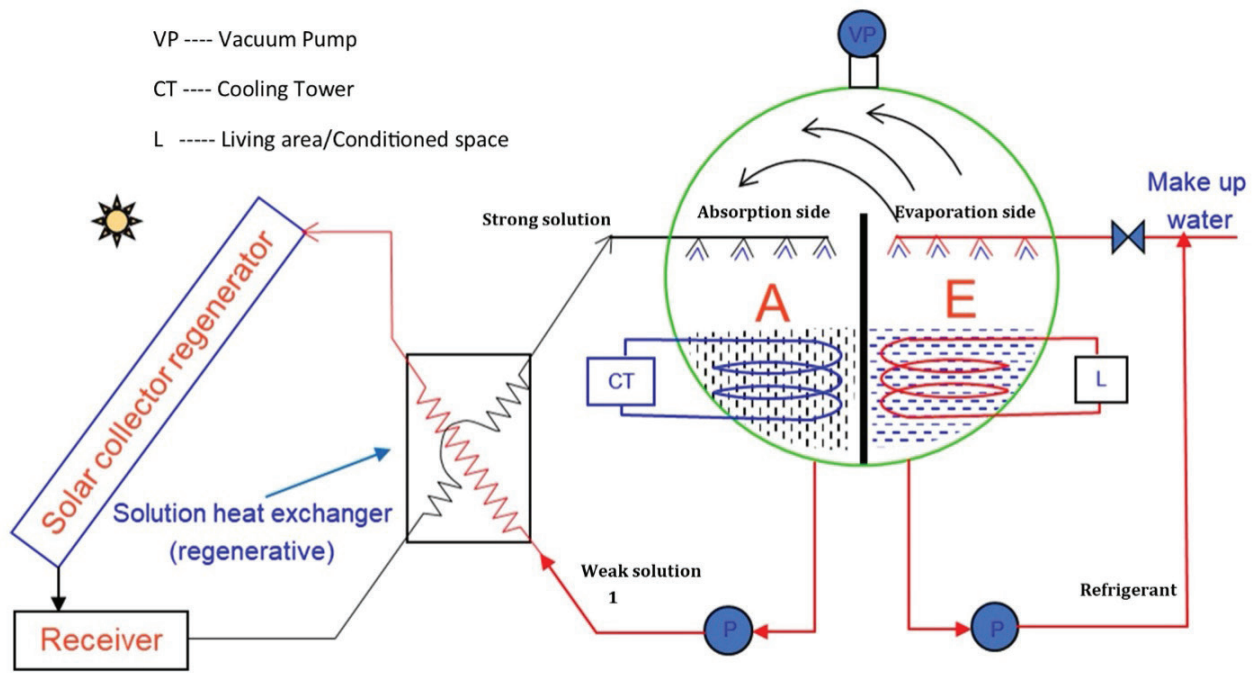

Figure 3. An open cycle absorption solar air-conditioning system.

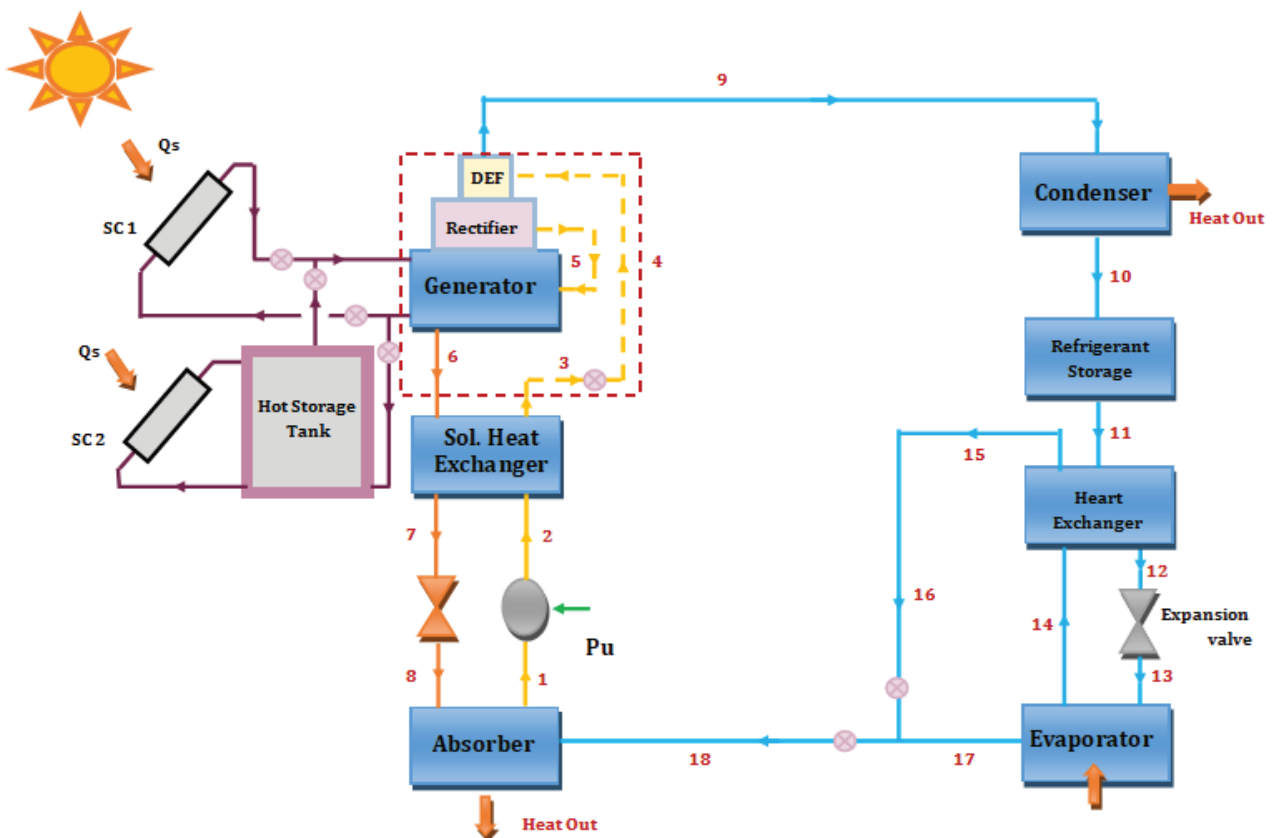

Figure 4. Continuously operated solar-driven absorption refrigeration system.

Other absorption refrigeration systems

Another sort of absorption system is an ejector-aided absorption system. The parts of these kinds of systems are similar to those of the continuous operation absorption refrigeration systems, but there is an addition of ejectors in the system [15]. Ejectors can be connected to the absorption system in several ways. The condenser or absorber intake could house the ejector. On the same basis, ejectors might be employed instead of throttling valves in AB systems. In absorption systems, the connection of ejectors aids in the decrease of refrigeration and generation temperatures [16]. Ejectors are capable of increasing pressure without exploiting any kind of compression work. Thus, utilizing an ejector is a simpler and safer way which could increase pressure, similar to an electrical compressor [17]. Evaluated the possibility of deploying a solar-driven ejector coupled absorption cooling system with $\text{NH}_3\text{-H}_2\text{O}$ as the working pair in 17 Turkish cities. In their calculations, the ejector was placed at the absorber intake, therefore, the pressure in the absorber was greater than the pressure in the evaporator, allowing the system to run at triple pressure. The ejector position was intended to increase evaporator pressure recovery, mixing, and pre-absorption by the evaporator's weak ammonia solution [18,19]. A 4.5 kW solar-operated absorption refrigeration system with cold storage using $\text{H}_2\text{O-LiBr}$, the system was installed and tested in Cardiff, UK. The vacuum tube collectors had a 12 m^2 area and a collector liquid based on ethylene glycol. The chiller's minimum activation temperature was 80°C . The cold water produced ranged in temperature from 7 to 16°C . The daily mean cooling COP was about 0.58, while the daily mean

electrical COP was about 3.6. The author suggested the system for the winter season combines the solar-operated cooling system with the heating and hot water systems [20]. Solar-operated absorption system with $\text{LiBr/H}_2\text{O}$ having a capacity of 10 TR with a 72 m^2 evacuated tube solar collector. The results showed that solar power generated 81% of the required electricity for the cooling system, with an LPG-fired auxiliary heating unit supplementing the remaining 19% [21,22]. Mazloumi et al., investigated a solar-operated absorption system with a peak cooling demand of 17.5 kW. The authors recommended a horizontal N-S parabolic trough collector with an insulated heat storage tank for the design. A minimum collector area of 57.6 m^2 is required to meet the required cooling load. The flat plate or the evacuated tube collectors require a broad installation area for spaces that demand substantial cooling load levels, which is typically impracticable [23]. In areas with convenient displays, parabolic trough collectors are more efficient in terms of solar thermal energy collecting. In contrast to stationary collectors, which rely on direct sunlight, the cooling system can start earlier and even continue to work in the absence of direct sunshine.

Helm et al. [24], suggested a solar-operated absorption system storage with low-temperature latent heat storage and a dry air cooler with cooling and heating modes respectively as shown in Figure 5. The performance parameters of this system were compared to that of the conventional V-C system having a cooling tower. During low-temperature times, the heat evacuated from the absorption chiller is stored and released into the ambient. It is easier to deploy absorption technology in an application without a cooling

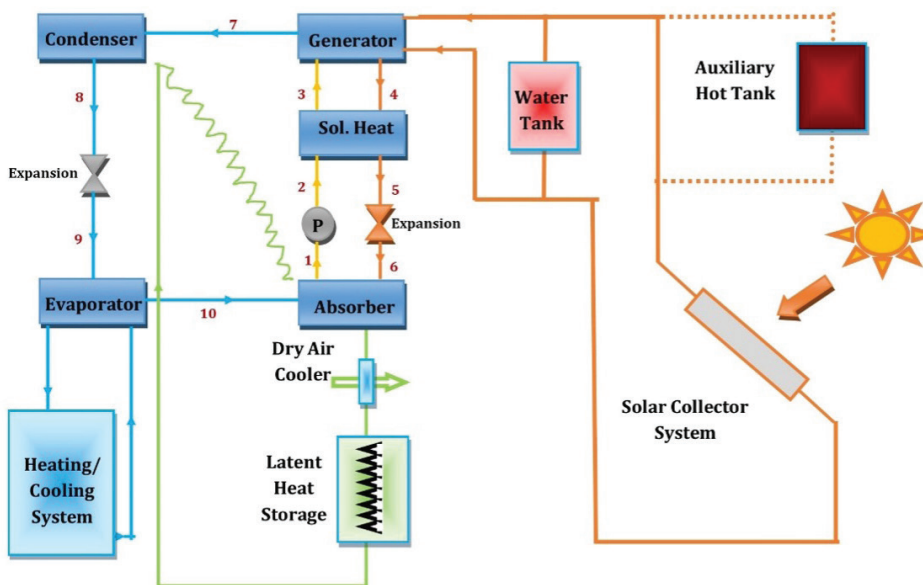

Figure 5. Hybrid absorption system in cooling/heating mode.

Table 2. Literature overview of absorption refrigeration systems

Working pair	Cooling capacity (kW)	Working Temps. (°C)	COP	Features/results	Ref.
LiBr-H ₂ O	300	T _G = 60 to 90 T _A = 33 to 39 T _C = 33 to 39 T _E = 4 to 10	0.73 to 0.79 (SE) 1.22 to 1.42 (DE) 1.62 to 1.90 (TE)	The optimum generator temperature was determined by modifying the condenser and evaporator temperatures. The performance parameters of SE, DE, and TE absorption systems were compared.	[25]
LiBr-H ₂ O	106	T _G = 80 T _A = 39.6 T _C = 38.2 T _E = 6	0.7	The temperature outside ranges from 40.3°C to 13.2 °C. When compared to the other components, the collector has a total exergy loss of 10–70%.	[26]
LiBr-H ₂ O	10.77	T _G = 90 T _A = 32.7 T _C = 40.2 T _E = 1.3	0.74 (ASPEN) 0.72 (EES)	The outcomes of the ASPEN simulation software were compared to the results of the EES software. The single effect and double impact LiBr–water systems were modelled. The results showed errors of less than 3% and 5% for single and double effects respectively.	[27]
LiBr-H ₂ O	11.31	T _G = 84.6 T _A = 36.2 T _C = 38 T _E = 5.5	0.74	The hot water storage tank of 800 liters was installed. A flat plate solar collector having a tilt angle of 35°C and collector area of 30 m ² is employed.	[28]
LiBr-H ₂ O	2355.45	T _G = 87.8/140.6 T _A = 37.8 T _C = 37.8 T _E = 7.2	0.6 to 0.75 (SE) 1 to 1.28 (series flow DE)	The energy and exergy concepts were applied to a SE and DE absorption system with LiBr–water system. The results show that the COP of the series flow DE system is 60 to 70% more than the COP of the SE system. While the optimal exergetic efficiency is achieved at 80°C for the SE system and 130 °C for the DE system.	[30]
LiBr-H ₂ O	10	T _G = 90 T _A = 40 T _C = 35 T _E = 5	0.77	Theoretical analysis of a LiBr-H ₂ O absorption system. The generator was found to have the greatest exergy loss component, accounting for 45.6% of the total exergy loss in the system. The refrigerant heat exchanger and pump show the minimum exergy loss in the system.	[31]
NH ₃ -H ₂ O	10	T _G = 166 T _A = 40 T _C = 40 T _E = -7	0.45	The maximum variation from the experimental results was 1.8%. Above the rectifying column, a divider was used. Using a separator resulted in a 15–20% increase in COP.	[32]
NH ₃ -H ₂ O	6.17	T _G = 145 T _A = 45 T _C = 51 T _E = 3.5	0.52	Energy and exergy analysis was carried out. 30% heat energy dissipation in the regenerative heat exchanger and rectifier. In the absorber, liquid and vapour phases dissipate 6% and 3% of the energy, respectively.	[33]
NH ₃ -H ₂ O	10.5	T _G = 165 T _A = 58.6 T _C = 54.5 T _E = 4.8	0.56	The system time constant drops as the NH ₃ concentration in the strong solution increases. There is an optimum generator volume, as well as mass and concentration of the strong solution, for obtaining maximum performance. For lowering the system time constant, a stepwise increase and decrease are recommended.	[34]
NH ₃ -H ₂ O	5	T _G = 80 T _A = 46 T _C = 42 T _E = 10	0.34	A two-stage system analysis was carried out. The absorber and condenser are cooled by direct air. Several air-cooling sequences were tested.	[35]

Table 3. Solar collector-operated designs of various absorption refrigeration systems

Absorption Systems (Pair)	Cooling capacity (kW) and Evap. Temp. T_E (°C)	Solar collector	Total aperture area (m ²)	Hot water Temp. (°C)	COP	Ref.
Single effect (LiBr-H ₂ O)	70, $T_E = 7$	Flat plate collector	160	88	0.6	[36]
Single/double-effect (LiBr-H ₂ O)	4.5–11, $T_E = 9$	Flat plate collector	48 / (42)	113/ (185)	0.6/ 1	[37]
Single effect (LiBr-H ₂ O)	23, $T_E = 10$ to 14	Parabolic trough collector	56	50–90	0.11–0.27	[38]
Double-effect (LiBr-H ₂ O)	116, $T_E = 6$	Parabolic trough collector	360	180	1.2	[39]
Double-effect (LiBr-H ₂ O)	346, $T_E = 7$	Parabolic trough collector	532	180	1.3	[40]

Table 4. Few absorption chillers available commercially

Manufacturer (Country)	Product	Working pair	Cooling capacity (kW)	COP	Hot water Temp. (°C)	Chilled water Temp. (°C)	Ref.
EAW (Germany)	Wegracal Maral 1/ Maral 2	LiBr-H ₂ O	15, 30, 50	0.71	80–90	17/11	[41]
Yazaki Energy (Japan)	WFC-SC5 / WFC-SC10	LiBr-H ₂ O	17.5, 35.2	0.7	88	7	[42]
Purix (Denmark)	A25	LiBr-H ₂ O	2.5	0.81	80	13	[43]
SonnenKlima (Germany)	Suninverse 10	LiBr-H ₂ O	10	0.76	75	15	[44]
Carrier (Poland)	16LJ / 16LJ-F	LiBr-H ₂ O	80-4000	0.78	80-90	12/7	[45]
AGO (Germany)	Ago Congelo	NH ₃ -H ₂ O	50	0.6	95	0	[46]
SolarNext (Germany)	Chilliii' Cooling Kits WFC	LiBr-H ₂ O	18-200	0.7	70-95	6/15	[47]
SolarNext (Germany)	Chilliii' Cooling Kits PSC	NH ₃ -H ₂ O	20-50	0.5	70-98	5/-10	[48]
Pink (Austria)	PSC19	NH ₃ -H ₂ O	18.6	0.62	85	6	[49]
Thermax (India)	L5 Series	NH ₃ -H ₂ O	35-700	0.75	75-120	1/-2	[50]

tower, especially in smaller installations. Unlike solar collectors in typical systems with wet cooling towers, storing latent heat minimizes the size of the system. The variation was due to the use of chilly, dry air. The researchers employed calcium chloride hex hydrate with a phase transition temperature of 27°C to 29°C for the experiment. It is a phase-change material (PCM) that transitions from melting to solidification. As a result, better volumetric storage was attained, estimated to be 10 times more than in the case of water heat storage.

Case Studies for a Solar Operated Absorption System

This section provides a brief overview of the solar-operated absorption system. Table 3 summarizes the major component conditions for a few solar-operated absorption systems studied in the literature, including working pair, cooling capacity with evaporator temperature, type of collector, total aperture area, hot water temperature, and COP. All systems used water or thermal oil as

operating fluids. The component specification has been discovered to be crucial when selecting chillers for a certain application.

Few Absorption Chillers Are Available Commercially

This section provides an overview of the absorption chillers available commercially. Table 4 shows a few absorption chillers available commercially with various operating ranges and other parameters.

ADVANCES IN SOLAR-OPERATED ABSORPTION CYCLES AND INNOVATIVE CONCEPTS

It is well known from the basic thermodynamic considerations that for an ideal absorption cycle, an increase of the heat supplied temperature and reduction of the sink temperature can improve the COP. The actual COP is much less than the ideal value due to irreversibilities, friction loss, and the nature of the working fluids.

It may be mentioned here that the overall actual efficiency of the currently available absorption refrigerating unit or heat pump system is even lower while we relate their consumption of power to the theoretical needs at the particular component temperature bounds. At this stage, improvements in absorption systems include lowering the generator temperature required for system operation, increasing the permissible cooling water temperature, and increasing the coefficient of performance. These goals are frequently mutually exclusive, and while significant improvements can be made in each of these circumstances by increasing the size of the heat exchanger surfaces in the system, this is generally unsatisfactory due to the related cost increase. The system modifications which improve performance should not increase the cost of the system. Recent developments in advanced solar collectors and collector-mirror systems focus to deliver heat at higher temperatures with reasonable collection efficiency and hence the utilization of absorption chillers with higher temperatures of heat supply is possibly further promoted. The feasibility of increasing the allowed cooling water temperature is of particular importance since significant cost savings can be gained by installing heat exchangers for heat rejection from the sinks of the absorption system. This is also preferable due to the significant maintenance costs associated with cooling tower operation. Due to the high cost-benefit ratios, solar-powered vapour absorption refrigeration systems have had little commercial success thus far. The main cause of this disadvantage is the low COP associated with these systems, which generally run on standard thermodynamic cycles and working fluid combinations. To increase the performance of a solar-powered refrigeration system, it is critical to research the use of different working fluids that operate on novel thermodynamic cycles.

Combined absorption-resorption cycle (CAR cycle)

Figure 6 shows a conventional NH₃-H₂O Absorption-Resorption cycle. The cycle has two solution circuits namely absorption and the resorption loop, connected via two streams of ammonia/water solution. In the absorption circulation loop, ammonia vapour from the desorber enters the absorber and gets absorbed in the solution at state 4. This solution is pumped to SHX1, gets preheated, and enters the generator, where heat is supplied to generate ammonia vapour. The generated vapour was sent to the resorber, while the solution with less amount of refrigerant (ammonia) returned to the absorber, while exchanging heat with the incoming solution stream in SHX1. In the resorption circulation loop, the ammonia vapour from the generator of the absorption circuit is absorbed in the resorber at state 6. The rich solution from the resorber exchanges heat with the poor solution in SHX2 and further reduces its pressure via throttle valve and the heat is taken from the conditioned space in the desorber.

Figure 7 shows the modified absorption-resorption cycle having a rectifier and the bleeding stream to connect the two solution circuits. The vapours from the generator of the absorption loop and pass through the rectifier to remove the water particles to enter the resorber of the other circuit in order to avoid freezing of water particles in the connecting pipeline. The bleeding or mixing connects the two solution loops, to equilibrate the mass balance in both the loops, the resorption circuit's (high-pressure side) excess water can be transported to the (low-pressure side) absorption loop.

Effect of Nanofluids in Solar Collectors-Based Absorption Cooling Systems

The ability of developed nations to lessen the environmental effects of burning fossil fuels to produce energy

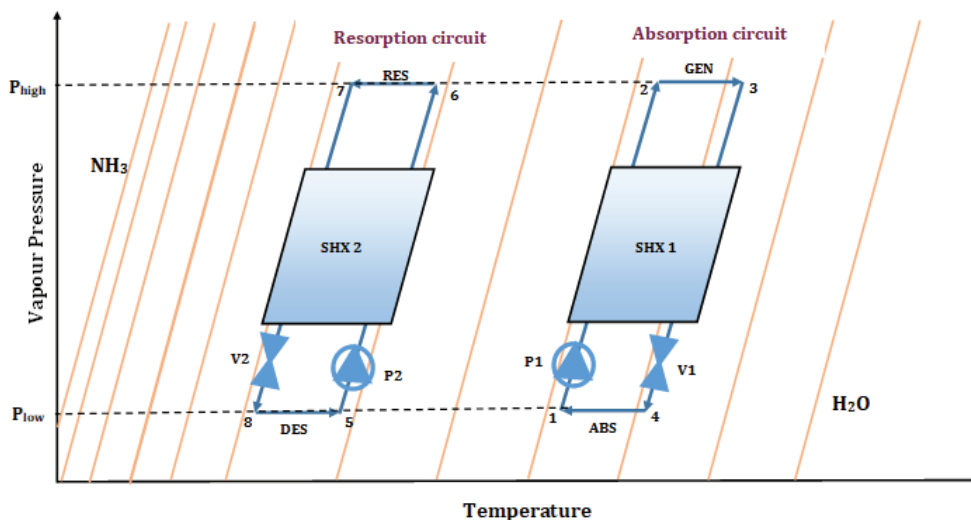

Figure 6. Basic absorption-resorption cycle.

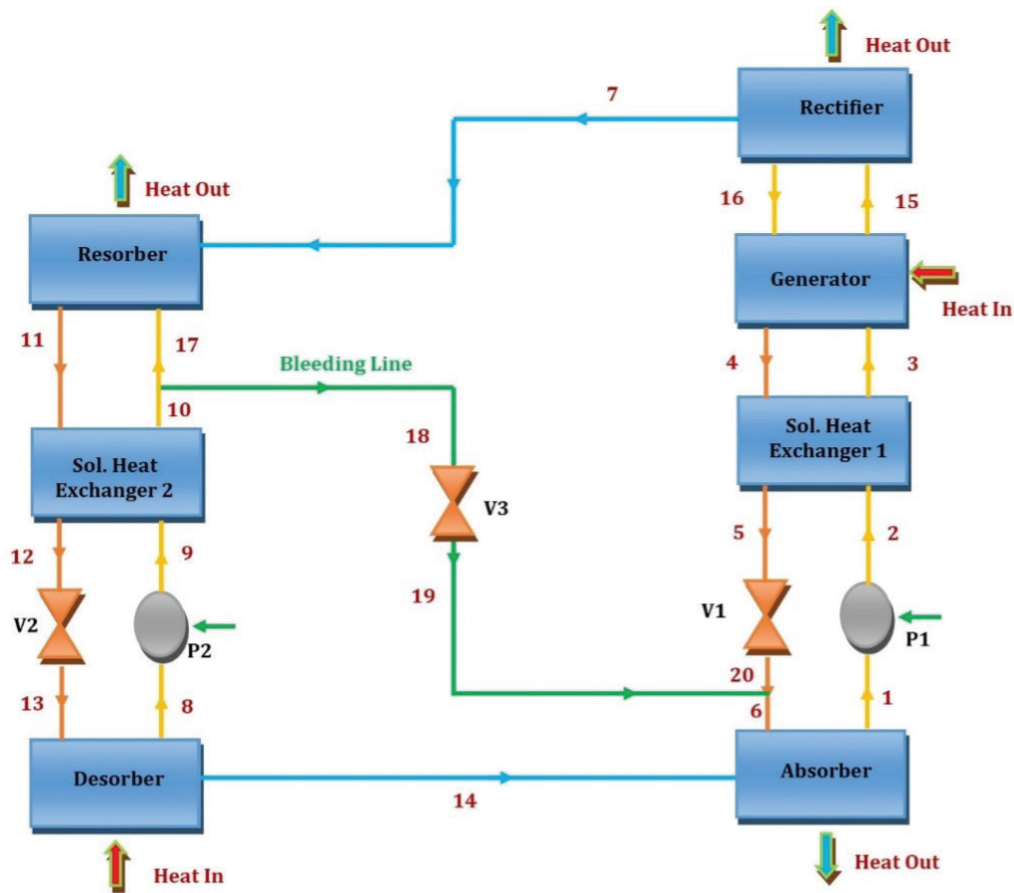

Figure 7. Basic absorption-resorption cycle.

can be improved through the use of nanotechnology. It has many uses, including theoretical and experimental research on geothermal, wind, biomass, solar, hydrogen, and tidal energy [52]. The use of nanofluid in direct absorption solar collectors can significantly improve the effectiveness of these devices. To improve solar-operated absorption and boost solar collector efficiency, nanoparticles must be evenly distributed [53] throughout the base fluid [54]. In comparison to a conventional collector, the nanofluid-based solar collector had a lower embodied energy (by about 9%) and slightly higher levels of pollution offsets (by about 3%) [55]. The thermal and optical performance of collectors can be significantly enhanced with better solar energy utilization by using phase change material in the collector glazing [56]. Increases in melting temperature of PCM, latent heat, and density have been found to improve thermal performance [57]. The appropriate volume concentration of nanoparticles is a crucial component. A solution with a higher volume fraction of nanoparticles becomes viscous and reduces heat transfer, whereas a solution with a lower value would not be able to absorb enough solar radiation [58].

The use of a corrugated insert can improve the efficiency of a parabolic trough solar collector (PTC) system

because it improves the tube receiver's overall heat transfer performance [59]. The outlet fluid temperature, energy efficiency, and exergy efficiency were all improved by the flat plate collector's use of elliptical pipes filled with turbulent nanofluid flow [60]. In order to power the ejector air conditioning system with water as the refrigerant, solar energy has been converted into thermal energy using a linear Fresnel solar reflector [61]. The enhancement of optical properties through the use of carbon nanohorns as nanoparticles [62]. The solar absorption efficiency could be significantly increased by carbon black nanofluids, which had good solar energy absorption capacity [58].

Recent Developments in Solar Absorption Refrigeration Systems

Under climate conditions in Australia, Nikbakhti and Iranmanesh [63] explained the utilization of solar energy to produce refrigerating output using a unique integration of an adsorption-absorption cooling system as indicated in Figure 8(a-b). Two distinct solar-operated configurations were studied, one with and one without a hot water storage tank. There was no production of cooling energy at the starting and end of the cycle in the system having no

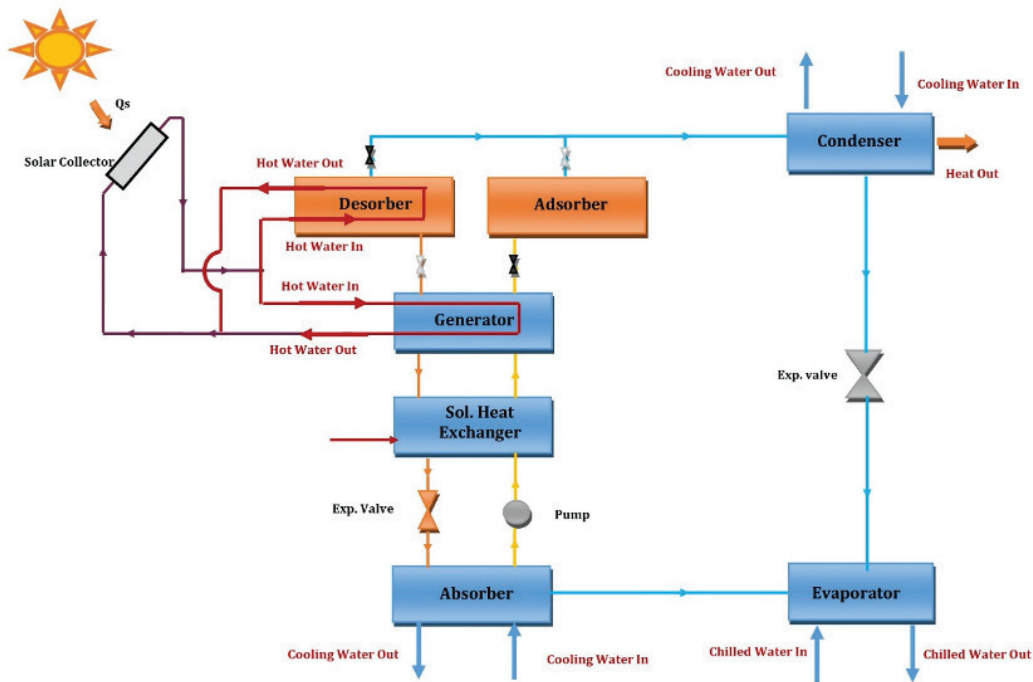

Figure 8(a). Solar-operated combined AD-AB refrigeration system (1st layout).

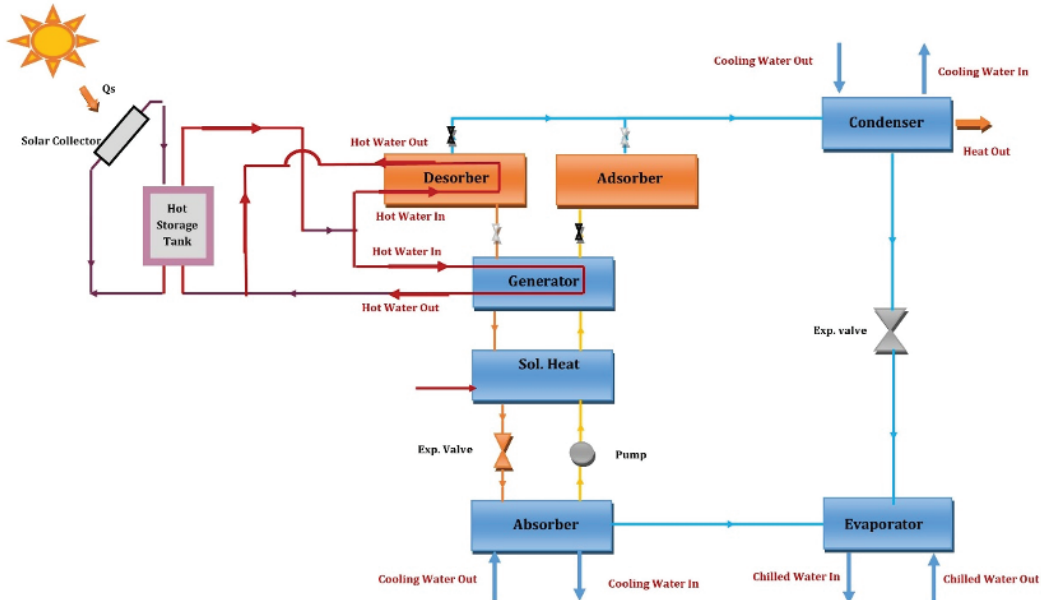

Figure 8(b). Solar-operated combined AD-AB refrigeration system (2nd layout).

storage tank, and the maximum cooling capacity of 16 kW was found at around 12:00 hrs. noon, while for the other system with a storage tank the maximum cooling capacity of roughly 15 kW was produced in the between 14:00 and 16:00 hrs. in the late afternoon, with increasing cooling capacity at the starting and finishing cycle times. It has been

found that constructing a storage tank with a large collecting area boosts average daily cooling capacity by 15% with a higher COP. The findings of the economic study reveal that the lifecycle cost for the commercially viable collection area of 34 m² is minimized. Furthermore, the optimal collecting area has a payback period of about 10.46 years indicating

that the proposed cooling system for solar energy usage was a lucrative option over a 25-year project investment.

Fitó et al. [64] described a novel absorption system having an energy storage option that is powered by low-temperature solar heat, it includes a SE absorption cycle coupled to a thermochemical process that employs the same evaporator, condenser, and working fluid as illustrated in Figure 9. At condenser temperature of 30°C, evaporator temperature of -10°C, and heat source temperatures of about 80°C, LiNO₃ salt was found to be a suitable sorbent for the absorption subsystem, while PbBr₂, BaCl₂, LiCl, SrCl₂, SnCl₂, and NH₄Br, were suitable reactive salts in the thermochemical subsystem for the same operating conditions.

The parametric research reveals that the absorption subsystem with NH₃-LiNO₃ gets near-maximum COP under the specified conditions, but the thermochemical subsystem obtains the highest COP with the NH₃-BaCl₂ pair. A new measure, the Coefficient of Demand Satisfaction (CSD), was formulated to quantify demand coverage. The hybrid system can reach up to a 24% greater CSD than the conventional system, depending on the size of the solar collector field and the amount of refrigerant stored by the thermochemical subsystem. Al-Nimr and Mugdadi [65] offer an innovative hybrid absorption system powered by a concentrated photovoltaic (CPV) thermal unit, as depicted in Figure 10. The PV module powers the thermoelectric cooler, and the thermal energy powers the absorption

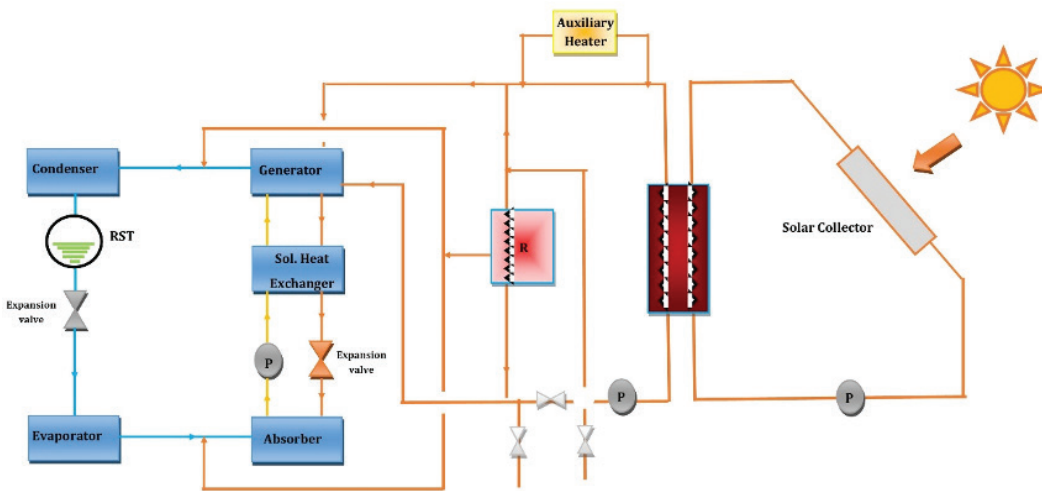

Figure 9. Solar-powered absorption-thermochemical cooling system.

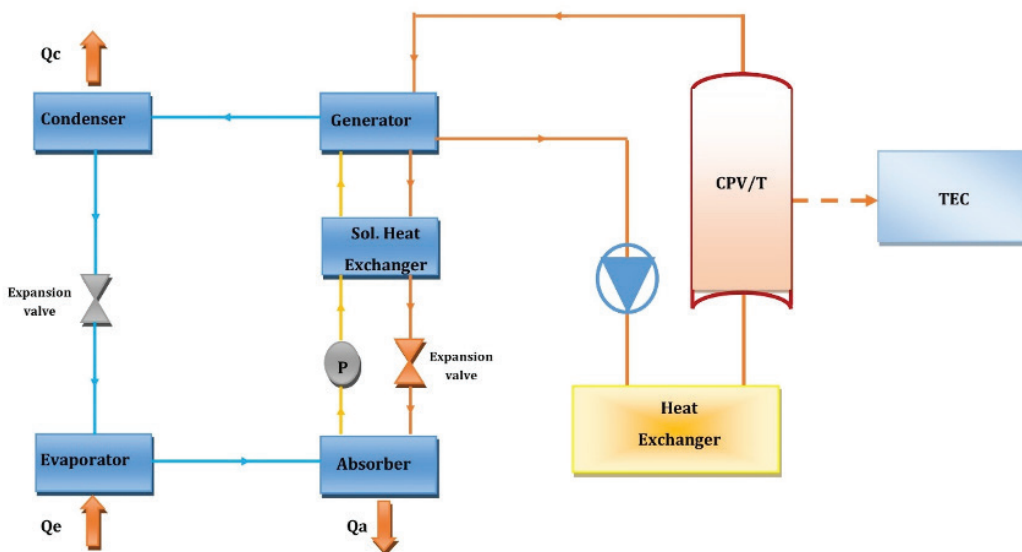

Figure 10. Solar-powered hybrid absorption system.

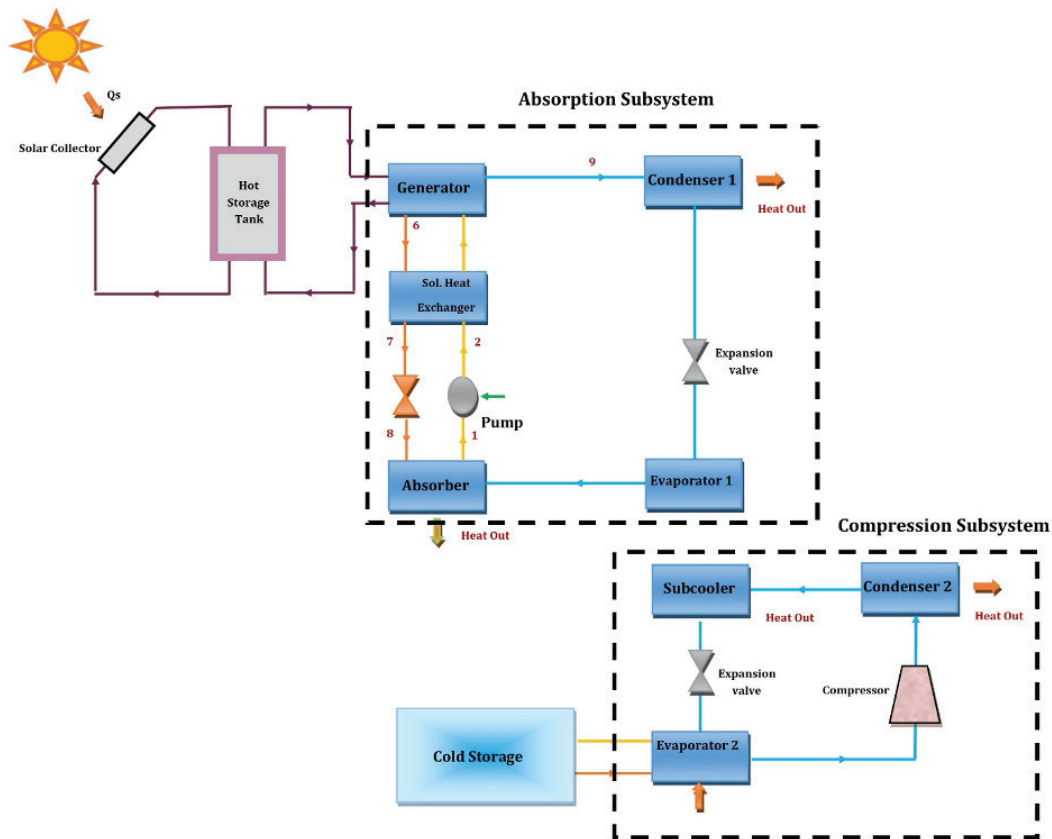

Figure 11. Solar operated absorption-compression hybrid system.

cooler. The PV module’s effective cooling offers greater power but lower thermal energy quality (temperature). As a result, the thermoelectric cooler provides greater cooling, and the absorption cooler provides less cooling. This study maximizes the overall cooling effect by optimizing the performance of PV panel cooling. The outcomes indicated that to carry out the optimization procedure, the COP of the thermoelectric cooler must be more than 6.4, implying a figure of merit of 70. When the temperature at the exit of PV/T rises from 65 to 90°C with the insolation of 1000 W/m², the overall COP of the system rises from 0.15 to 0.23.

Xu et al. [66], presented a financial and technical evaluation of the solar-operated hybrid absorption-subcooled compression refrigeration system, as shown in Figure 11. The impacts of absorption subsystem size and the amount of hot water in the storage tank were investigated. Furthermore, the genetic algorithm was used for global optimization. For the collector area of 2000 m², the size of the absorption subsystem 0.04 to 0.06 kW/m² having 40–60 L/m² as the volume of the storage tank was considered the best solution. The annual electric energy savings reached a maximum of 68.8 kWh/m². The solar-operated hybrid refrigeration system was economically viable for cold storage even without subsidies, with 4.96 years minimum pay-back period.

Jing et al. [67], established an exergo-economic design criterion for a solar-operated absorption system coupled with a subcooled compression refrigeration system, as shown in Figure 12, to optimize the cost and overall performance. The technique was employed in both low-rise and high-rise structures. Twenty-four samples were thoroughly studied with changing characteristics such as the absorption system size, the temperatures of the condenser and evaporator of the compression system, and the compressor isentropic efficiency. The exergoeconomic off-design model was initially done. Following that, the decision variables for various hot and cooling water temperatures, and the system load, were obtained and analyzed.

Arabkoohsar and Sadi [68], conducted a techno-economic analysis of SE, DE, and TE absorption systems powered by parabolic trough collectors (PTC) and waste incineration (WI) plants for trigeneration of power, heat, and cold in Denmark, as shown in Figure 13. The outcomes showed that using parabolic trough collectors, irrespective of the kind of absorption system solves the purpose in summer. Furthermore, compared to the single-effect system, DE and TE absorption systems reduce the price of the hybrid system by 45% and 50%, respectively. Out of the various configurations, the hybrid system combined with the TE absorption system showed optimal performance by

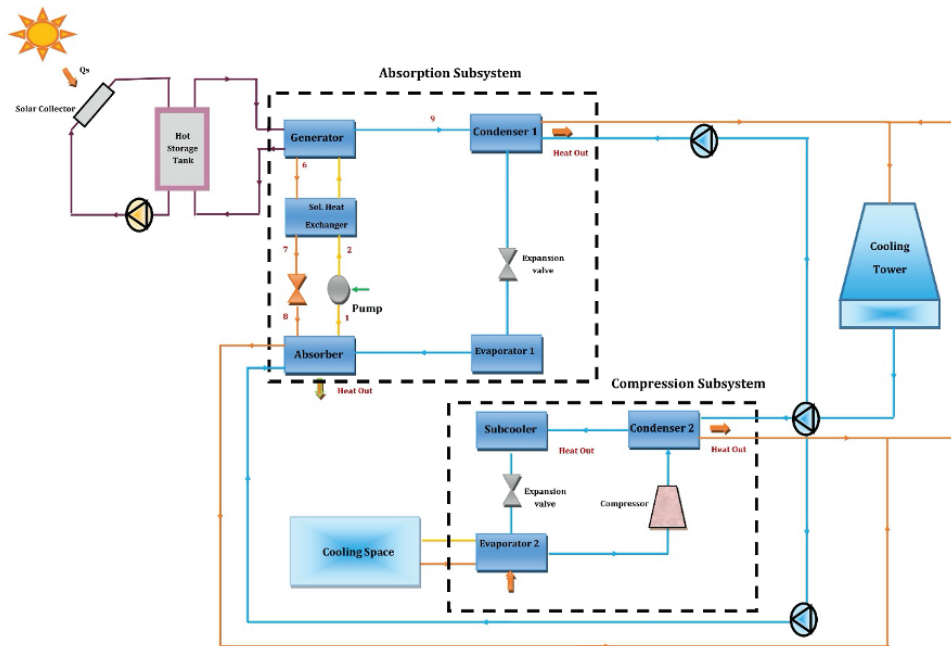

Figure 12. Solar absorption-subcooled compression cooling system.

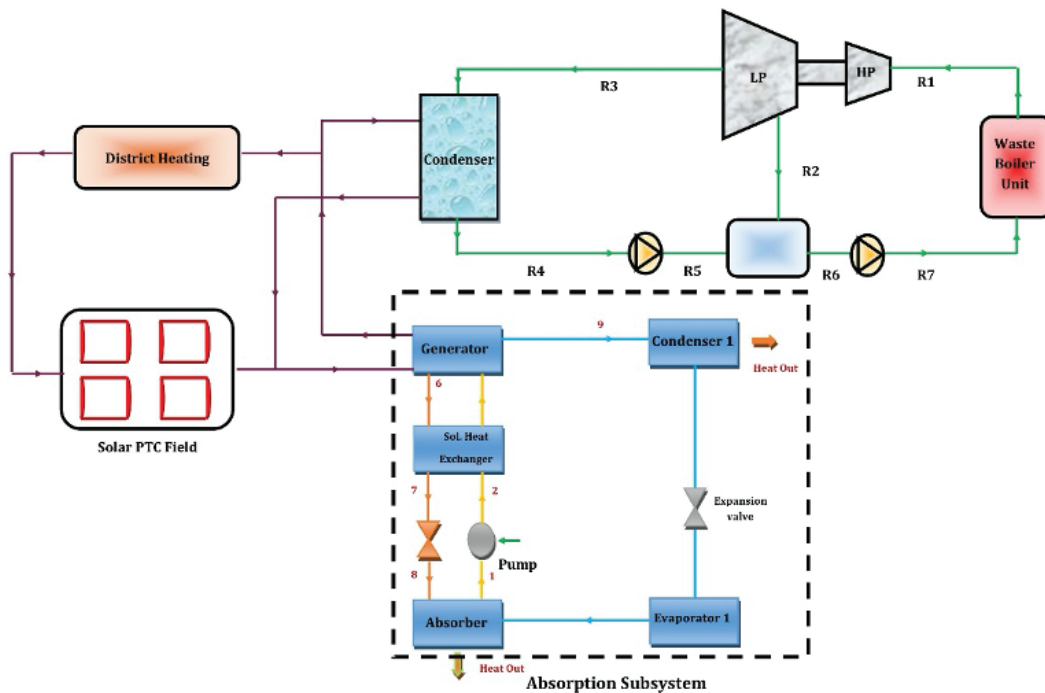

Figure 13. Schematic of a PTC-assisted absorption system with a district heating system.

lowering the number of collectors needed and the requisite flow rate of municipal solid waste and therefore lowering expenditures.

Bellos et al. [69], studied a 100-kW solar cooling system for the climatic conditions of Athens, Greece, which

comprises an evacuated tube collector (ETC), storage tank, and SE absorption system with LiBr-H₂O as the working pair as shown in Figure 14. Various sets of solar panel areas ranging from 150m² to 600m² were chosen, as were various sets of storage tanks ranging from 6 m³ to 16

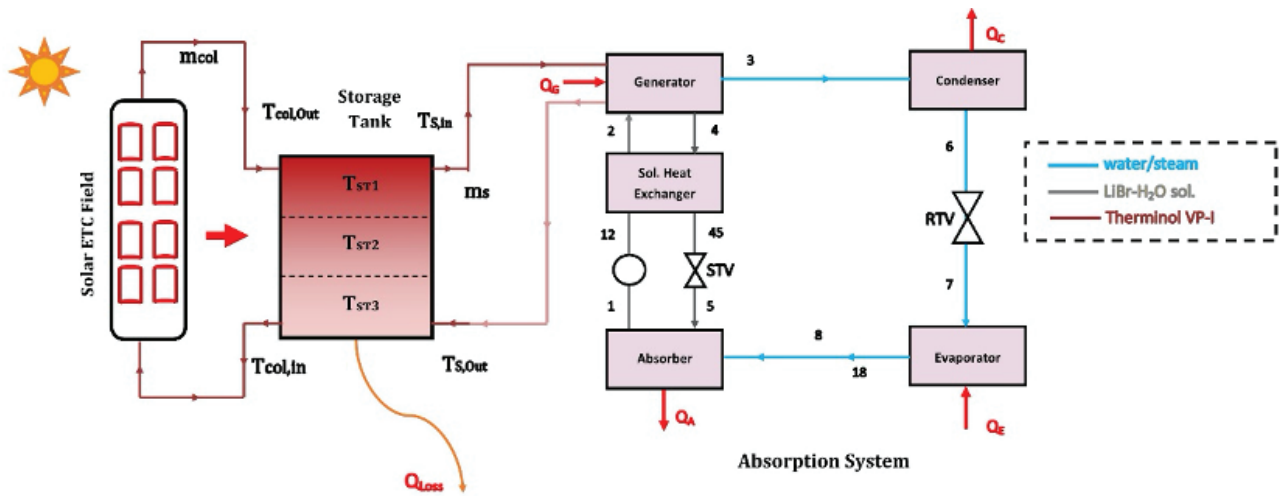

Figure 14. Schematic of an ETC-assisted absorption system.

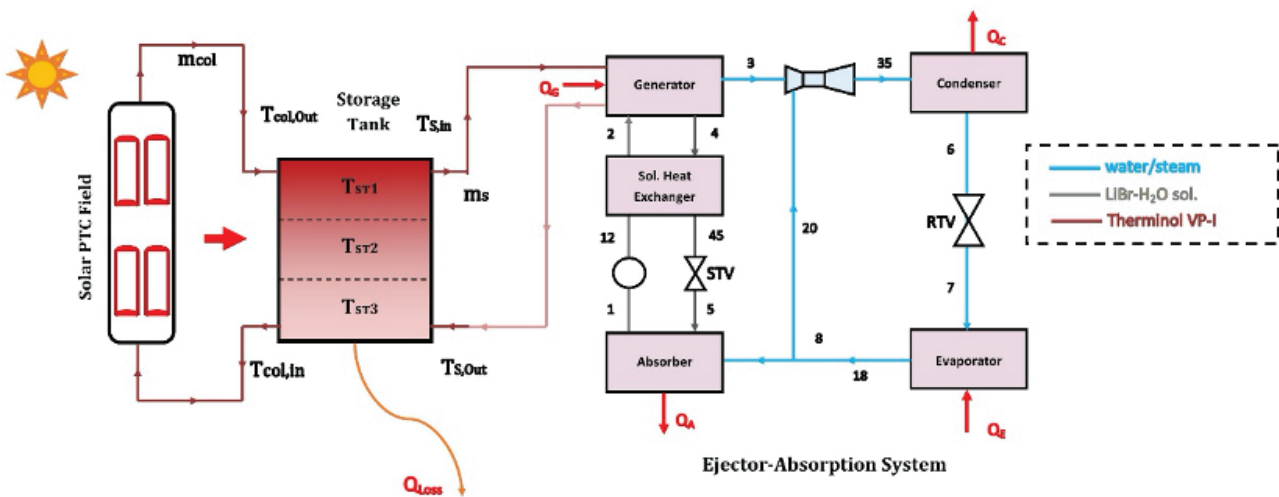

Figure 15. Schematic of a PTC-operated absorption-ejector refrigeration system.

m³. The best examples were evaluated financially, and the results revealed that 450 m² of ETC with a storage tank volume of 14 m³ was the best solution with a 15-year pay-back period.

Bellos and Tzivanidis [70], examined an absorption-thermo-compression refrigeration system having LiBr-H₂O as working fluid pair, by providing the heating based on parabolic trough collectors as shown in Figure 15. The pressure drop in the ejector and the temperature and pressure of the generator of the absorption system were the optimization parameters, for the maximization of COP as the objective function. An improvement of 60.9% in performance was recorded compared to the conventional absorption system when the condenser temperature was 30°C and the evaporation temperature was 12.5°C.

Prasartkaew and Kumar [71], designed a hybrid solar biomass-operated absorption cooling system as shown in Figure 16. This system (designed for domestic installation) has the following components: an absorption machine, biomass, a hot water boiler, and a solar-powered water heater with a storage tank, with the hot water boiler situated in the middle of the storage tank and the absorption system. When there is inadequate solar power, the insulated boiler serves as a backup boiler, and when there is no solar power, it serves as the primary source of heat. The chiller COP was 0.7, and the whole system COP was 0.55, with a daily charcoal usage of 24.44 kg for a continuous 24 hrs. operation. Bangkok was the site of the system installation. The proposed technology has various advantages in terms of reduced greenhouse gas emissions and greater comfort.

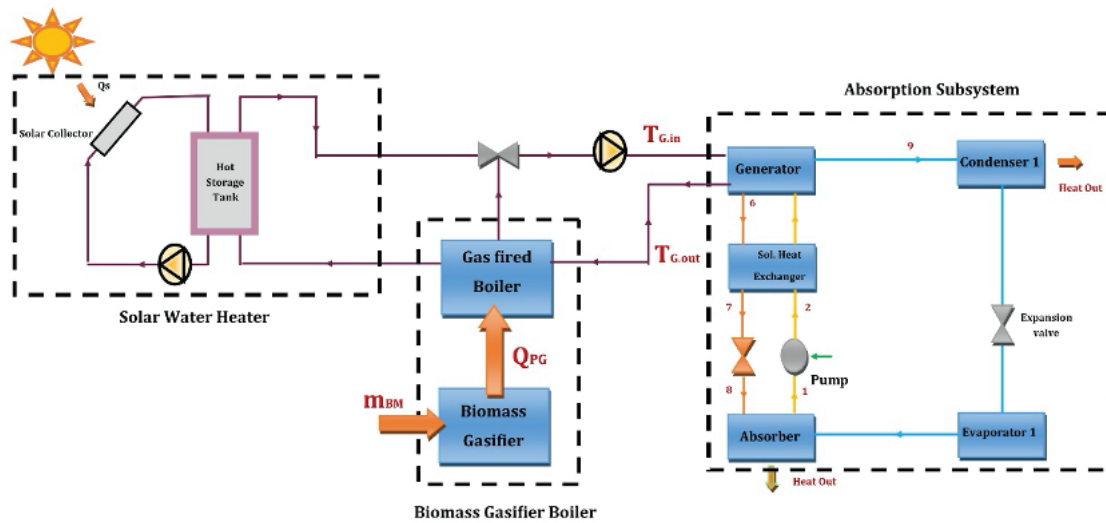

Figure 16. Solar biomass operated absorption cooling system.

Technical Barriers and Possible Remedies in the Development of Solar Absorption Cooling Systems

The system-level integration of solar absorption cooling is its primary technological shortcoming. Many systems fall short of the intended energy savings due to improper system design and energy management, which raises the overall electricity consumption of auxiliary components. The heat rejection subsystem, which has received too little attention in the past, is one of the areas where mistakes are frequently made. Another error is the overcomplexity of many systems, which leads to suboptimal control and extensive maintenance needs. According to the actual installation and operation of these systems, the key issue areas are:

- Heat rejection: Cooling towers frequently consume excessive amounts of electricity and are not part load regulated. Wet cooling towers with small capacities are expensive and require excessive amounts of work. Dry cooling towers require more electricity, and frequently, the chiller re-cooling temperatures are too high for solar thermal power. Although there are not many hybrid systems (dry/wet) on the market and they are not designed to work with thermally driven chillers, they appear to be a potential solution.
- High-efficiency auxiliary components, sophisticated leakproof pipework, and instrumentation play a significant role in the proper operation of the system. This is particularly important, as solar cooling systems need more attention than standard solutions.
- Further, the integration of all parts into a comprehensive system is another technical barrier. The overall system design needs professional skills for the various subsystems, including hydraulics with pressurized and medium-temperature water, solar energy at medium

temperature, and space conditioning or industrial cooling.

The economics of these systems is its second major barrier. The initial cost of installations has a first cost that is between 2 and 5 times greater than a typical, conventional refrigeration system. This must be decreased. The two main ways to get through this obstacle are (1) to concentrate on medium to large system sizes, which result in economies of scale, and (2) to standardize the systems as much as you can to minimize hazards and on-site labour. Policy approaches that enable a cost-reflective method of internalizing electricity grid expenses into the initial purchase cost of solar cooling systems should also receive significant attention. The state of this technology is critical, there are installations that have been observed, and major components of this technology are readily available. The technology has advanced to the point of early market deployment and has demonstrated the feasibility of significant energy savings. The following steps ought to be a few of the possible remedies to tackle the problems associated with this technology:

- Establishment of technology-specific standards and requirements for systematic quality assurance. International guidelines or regulations should be established expressly for the use of this technology for solar cooling. Such guidelines would assist in providing users with essential confidence in the degree of energy savings and associated cost savings.
- Deployment of specialized training for project-related players, to lower the installation and maintenance cost of this technology. Implementation of industry or governmental assistance programs that would provide technology incentives. It would support the market development of a competitive supply chain and economies of scale.

The most crucial actions should enable sustainable market growth. This includes the creation of extensive demonstration programs with (1) rewards and (2) standards for quality assurance that work together to promote adoption and reduce risk. At both the regional and national levels, these initiatives should be planned. They ought to be promoted initially in areas of the world where cooling is a major problem and environmental considerations are a top priority. To meet the expectations of all engaged stakeholders, it is crucial to implement quality procedures that are reviewed thoroughly at every stage of the project. In the near future, quality assurance and support measures for solar cooling systems need to be widely publicized.

ECONOMICS OF SOLAR COOLING SYSTEMS

Solar cooling can have a significant environmental impact by lowering the use of fossil fuels and is established enough to compete with traditional cooling systems. Most of the renewable energy installations have high starting costs. This is especially true for solar cooling systems [72]. The high cost of building and installation of solar energy systems is one of their key characteristic features. A large collector is needed due to the dispersed nature of solar energy. The benefit of a solar system is that once it is built, a significant portion of the energy input is free, in contrast to a conventional system where the cost of energy is an ongoing investment. Due to the fact that the peak of cooling demand coincides with the availability of solar radiation, solar cooling systems could be a practical alternative for space cooling in residential buildings [73]. The general standard for determining if a solar system is economically viable is whether the cost value of the energy saved by operating the system over the course of its lifetime exceeds the additional costs associated with installing the system. The amount of energy saved and the cost of the conventional energy source that the solar system is replacing determine the value of the energy saved by the installation. The regional climate has an impact on the economic viability of solar-powered absorption cooling, both in terms of higher thermal energy generation and in terms of the size of the absorption chiller [74]. The amount of energy saved varies depending on the load size, climate zone, and the type and size of the system installed.

Various methods are available for different types of the solar system that allow the designer to determine the percentage of the load's energy demand that the solar system can supply. Estimating the future values of the energy savings provided by the system is a tough undertaking that makes it difficult to economically justify a solar energy system. As the cost of conventional energy rises, more solar applications will become economically attractive and competent with conventional energy [75]. Solar-powered

passive house heating/cooling systems are possible cost-effective alternatives to applications for household hot water and other applications. Despite the fact that solar energy is completely free, it is necessary to have more equipment for solar-powered cooling systems than for conventional cooling systems, which results in higher capital expenditures. Solar-powered cooling systems can function with solar energy that is not always present during the winter season because they are hybrid in nature. The difference between the energy cost for a conventional system and the cost of the auxiliary energy source needed for the solar system, then, there is a decrease in annual energy cost for cooling that may be achieved with a solar system. The overall economic viability of a solar system is the key criterion for deciding whether to deploy it. Also, High full load hours are essential for an economic performance because capital expenditures make up the majority of the costs for absorption cooling systems [76].

One of the popular techniques for assessing the economics of solar energy is the payback period approach. The cost value of the energy saved in the first year is divided by the system's total cost in this technique. This provides a timeframe for when the energy savings will equalise the initial investment. The cost effectiveness of the solar system will significantly increase using this strategy, which does not account for the anticipated rise in the cost of conventional electricity. Thus, under the presumptive operating conditions, the payback period precisely connects the additional capital cost of the solar equipment to the value of the energy saved. This method, which is very simple, offers a fundamental indication of economic viability at the current stage of solar system development. Buildings that have solar cooling (and heating) systems installed might eventually be thought of as real estate investments that typically increase in value over time. Payback and other capital payback methods based on energy savings would be limited in their application in such circumstances. The cost of solar-powered refrigeration and cooling systems is extremely difficult to measure, as it is with many other solar energy applications. People participating in research and/or monitoring activities are less hopeful about the prospects for active solar cooling systems in the future because of their intimate involvement. However, solar-powered cooling solutions are favoured over conventional cooling apparatus that is mostly imported. Solar cooling and refrigeration would become more crucial as the energy required for space cooling increased quickly and ice manufacturing became necessary in isolated regions.

Despite being less expensive than the other sorption cooling technologies, ejector systems have very poor COPs and high unit costs. In terms of performance, adsorption and absorption cooling technologies are similar. However, adsorption systems are currently more expensive than absorption systems [77].

Table 5. Cycle COP and cost comparison for various cooling options

Cooling System	COP	Cost €/kW Cooling
VCR	3	2500
Single effect Absorption	0.8	1100
Double effect Absorption	1.2	1300
Vapour adsorption	0.6	1400
Ejector system	0.3	1700
Thermo electric	2	3300

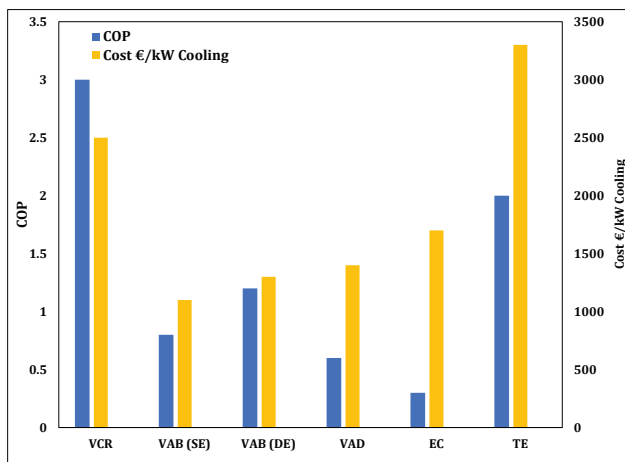
**Figure 17.** COP and cost for various cooling options.

CONCLUSION

It is evident that solar refrigeration and space conditioning systems have attracted a great deal of attention in recent years. In the present paper, the authors have reviewed the research of various authors on solar cooling systems in general and absorption cooling systems in particular. The following conclusions have been made based on the present study:

- All solar systems are capital intensive and usually more expensive in their initial costs compared to alternative conventional cooling systems. Solarizing cold storage holds great promise and potential in the coming future. Enhancement in performance due to configuration modifications can also reduce the cost of the system considerably as the required collector area decreases.
- Solar cooling has obvious possibilities owing to the correlation between the cooling load and the availability of solar radiation. Tropical and near tropical arid and semi-arid zones are favourable areas with reliable solar energy and a climate that demands enrichment for human comfort.
- Absorption systems have been extensively investigated for solar air conditioning systems. Undoubtedly, the

payback period of solar-powered cold storage is far too long to be cost-effective.

- The single effect absorption has been used for solar application. The performance of these single-effect machines for air conditioning is limited to COP of about 0.8. This level of performance is relatively low, and the equipment cost is relatively high. Thus, these systems cannot compete economically with conventional vapour compression systems.
- The double effect absorption systems have been used with solar applications, which can achieve COP in the range of 1.25 to 1.5. Simultaneous development of a low-cost high-temperature collector will be required to get solar energy economically.
- Despite the few constraints of solar cooling, there is much reason for encouragement on account of an increase in solar cooling research aimed at new concepts, matched to the advanced components. Solar collection temperatures at reasonable conversion efficiencies are being achieved and thus making practical use of air-cooled condensers.
- Better collections/storage systems are being developed to provide higher cycle efficiencies, reduced thermal losses, and higher reliability. The performance and reliability of the installed solar cooling systems are of great concern. The field of solar cooling is still diverging.
- A hybrid absorption system with solar energy and waste heat utilization shows promising results based on various factors such as the availability of solar radiation, the technology used, and the complexity of the system.
- The conventional approach for performance evaluation of solar cooling systems is based on Energy analysis (based on the First Law of Thermodynamics). However, Exergy analysis based on second law analysis is more desirable from the point of view of realistic performance evaluation of these systems.

Future research and development work on solar cooling should be aimed at the following system options:

- Rankine cycle-based solar cooling system
- Stirling engine-based Gas cycle solar refrigeration system
- Solar Metal Hydride Refrigeration system
- Open cycle absorption/adsorption systems
- Intermittent Absorption/Adsorption Systems and
- Jet ejector compression cooling option

Also, hybrid solar cooling systems for cost-effective space conditioning should be developed and investigated.

NOMENCLATURE

Abbreviations

COP	coefficient of performance
V-C	vapour-compression
V-A	vapour-absorption
CAR	Combined Absorption-Resorption
AD	adsorption

AB	absorption
SE	single-effect
DE	double-effect
TE	triple-effect
CSD	Coefficient of Demand Satisfaction
DEF	defragmenter
RO	reverse osmosis
EES	Engineering equation solver
CPV	concentrated photovoltaic
HX	heat exchanger
SHX	solution heat exchanger
PTC	parabolic trough collectors
PCM	phase-change material
LPG	liquified petroleum gas

Symbols

T_G	generator temperature (°C)
T_A	absorber temperature (°C)
T_C	condenser temperature (°C)
T_E	evaporator temperature (°C)
Q_p	collector heat flow rate (kW)
A_p	collector area (m ²)
t_p	average collector temperature (°C)
I_s	incident solar radiation (kW/m ²)
t_{in}	inlet fluid temperature (°C)
t_o	outlet fluid temperature (°C)
t_{air}	ambient air temperature (°C)
Φ	angle between the Sun and the normal to the collector

ACKNOWLEDGMENTS

The authors gratefully acknowledge the facilities and financial support to carry out the research from the Department of Energy Science and Engineering, Indian Institute of Technology Delhi.

AUTHORSHIP CONTRIBUTIONS

Authors equally contributed to this work.

DATA AVAILABILITY STATEMENT

The authors confirm that the data that supports the findings of this study are available within the article. Raw data that support the finding of this study are available from the corresponding author, upon reasonable request.

CONFLICT OF INTEREST

The author declared no potential conflicts of interest with respect to the research, authorship, and/or publication of this article.

ETHICS

There are no ethical issues with the publication of this manuscript.

REFERENCES

- [1] Kim DS, Infante Ferreira CA. Solar refrigeration options - a state-of-the-art review. *Int J Refrig* 2008;31:3–15. [\[CrossRef\]](#)
- [2] Gado MG, Ookawara S, Nada S, El-Sharkawy II. Hybrid sorption-vapor compression cooling systems: A comprehensive overview. *Renew Sustain Energy Rev* 2021;143:110912. [\[CrossRef\]](#)
- [3] Aliane A, Abboudi S, Seladji C, Guendouz B. An illustrated review on solar absorption cooling experimental studies. *Renew Sustain Energy Rev* 2016;65:443–458. [\[CrossRef\]](#)
- [4] Corrada P, Bell J, Guan L, Motta N. Optimizing solar collector tilt angle to improve energy harvesting in a solar cooling system. *Energy Procedia* 2014;48:806–812. [\[CrossRef\]](#)
- [5] Rossetti A, Armanasco F. Performance evaluation of a medium-temperature solar cooling plant. *Energy Procedia* 2015;81:1198–1211. [\[CrossRef\]](#)
- [6] Almasri RA, Abu-Hamdeh NH, Esmaeil KK, Suyambazhahan S. Thermal solar sorption cooling systems - A review of principle, technology, and applications. *Alexandria Eng J* 2022;61:367–402. [\[CrossRef\]](#)
- [7] Mustafa AA, Noranai Z, Imran AA. Solar absorption cooling systems: a review. *J Therm Eng* 2021;7:970–983. [\[CrossRef\]](#)
- [8] Choudhury B, Saha BB, Chatterjee PK, Sarkar JP. An overview of developments in adsorption refrigeration systems towards a sustainable way of cooling. *Appl Energy* 2013;104:554–567. [\[CrossRef\]](#)
- [9] Henning HM. Solar assisted air conditioning of buildings - an overview. *Appl Therm Eng* 2007;27:1734–1749. [\[CrossRef\]](#)
- [10] Kaynakli O, Kilic M. Theoretical study on the effect of operating conditions on performance of absorption refrigeration system. *Energy Convers Manag* 2007;48:599–607. [\[CrossRef\]](#)
- [11] Hamza A, Ali H, Noeres P, Pollerberg C. Performance assessment of an integrated free cooling and solar powered single-effect lithium bromide-water absorption chiller. *Sol Energy* 2008;82:1021–1030. [\[CrossRef\]](#)
- [12] Gomri R. Investigation of the potential of application of single effect and multiple effect absorption cooling systems. *Energy Convers Manag* 2010;51:1629–1636. [\[CrossRef\]](#)
- [13] Collier RK. The analysis and simulation of an open cycle absorption refrigeration system. *Sol Energy* 1979;23:357–366. [\[CrossRef\]](#)
- [14] Said SAM, El-Shaarawi MAI, Siddiqui MU. Alternative designs for a 24-h operating solar-powered absorption refrigeration technology. *Int J Refrig* 2012;35:1967–1977. [\[CrossRef\]](#)
- [15] Sriksirin P, Aphornratana S, Chungpaibulpatana S. A review of absorption refrigeration technologies. *Renew Sustain Energy Rev* 2001;5:343–372. [\[CrossRef\]](#)

- [16] Zhai XQ, Qu M, Li Y, Wang RZ. A review for research and new design options of solar absorption cooling systems. *Renew Sustain Energy Rev* 2011;15:4416–4423. [CrossRef]
- [17] Chen X, Omer S, Worall M, Riffat S. Recent developments in ejector refrigeration technologies. *Renew Sustain Energy Rev* 2013;19:629–651. [CrossRef]
- [18] Sözen A, Özalp M, Arcaklıoğlu E. Prospects for utilisation of solar driven ejector-absorption cooling system in Turkey. *Appl Therm Eng* 2004;24:1019–1035. [CrossRef]
- [19] Sözen A, Özalp M. Solar-driven ejector-absorption cooling system. *Appl Energy* 2005;80:97–113. [CrossRef]
- [20] Agyenim F, Knight I, Rhodes M. Design and experimental testing of the performance of an outdoor LiBr/H₂O solar thermal absorption cooling system with a cold store. *Sol Energy* 2010;84:735–744. [CrossRef]
- [21] Pongtornkulpanich A, Thepa S, Amornkitbamrung M, Butcher C. Experience with fully operational solar-driven 10-ton LiBr/H₂O single-effect absorption cooling system in Thailand. *Renew Energy* 2008;33:943–949. [CrossRef]
- [22] Mazloumi M, Naghashzadegan M, Javaherdeh K. Simulation of solar lithium bromide-water absorption cooling system with parabolic trough collector. *Energy Convers Manag* 2008;49:2820–2832. [CrossRef]
- [23] Verma A, Kaushik SC, Tyagi SK. Energy and exergy analysis of a novel ejector-absorption combined refrigeration cycle using natural refrigerants. *Int J Exergy* 2022;39:142. [CrossRef]
- [24] Helm M, Keil C, Hiebler S, Mehling H, Schweigler C. Solar heating and cooling system with absorption chiller and low temperature latent heat storage: Energetic performance and operational experience. *Int J Refrig* 2009;32:596–606. [CrossRef]
- [25] Gomri R. Second law comparison of single effect and double effect vapour absorption refrigeration systems. *Energy Convers Manag* 2009;50:1279–1287. [CrossRef]
- [26] Onan C, Ozkan DB, Erdem S. Exergy analysis of a solar assisted absorption cooling system on an hourly basis in villa applications. *Energy* 2010;35:5277–5285. [CrossRef]
- [27] Somers C, Mortazavi A, Hwang Y, Radermacher R, Rodgers P, Al-Hashimi S. Modeling water/lithium bromide absorption chillers in ASPEN Plus. *Appl Energy* 2011;88:4197–4205. [CrossRef]
- [28] Balghouthi M, Chahbani MH, Guizani A. Feasibility of solar absorption air conditioning in Tunisia. *Build Environ* 2008;43:1459–1470. [CrossRef]
- [29] Balghouthi M, Chahbani MH, Guizani A. Solar Powered air conditioning as a solution to reduce environmental pollution in Tunisia. *Desalination* 2005;185:105–110. [CrossRef]
- [30] Kaushik SC, Arora A. Energy and exergy analysis of single effect and series flow double effect water-lithium bromide absorption refrigeration systems. *Int J Refrig* 2009;32:1247–1258. [CrossRef]
- [31] Kilic M, Kaynakli O. Second law-based thermodynamic analysis of water-lithium bromide absorption refrigeration system. *Energy* 2007;32:1505–1512. [CrossRef]
- [32] Darwish NA, Al-Hashimi SH, Al-Mansoori AS. Performance analysis and evaluation of a commercial absorption-refrigeration water-ammonia (ARWA) system. *Int J Refrig* 2008;31:1214–1223. [CrossRef]
- [33] Chua HT, Toh HK, Ng KC. Thermodynamic modeling of an ammonia-water absorption chiller. *Int J Refrig* 2002;25:896–906. [CrossRef]
- [34] Kim B, Park J. Dynamic simulation of a single-effect ammonia-water absorption chiller. *Int J Refrig* 2007;30:535–545. [CrossRef]
- [35] Lin P, Wang RZ, Xia ZZ. Numerical investigation of a two-stage air-cooled absorption refrigeration system for solar cooling: Cycle analysis and absorption cooling performances. *Renew Energy* 2011;36:1401–1412. [CrossRef]
- [36] Rosiek S, Battles FJ. Integration of the solar thermal energy in the construction: Analysis of the solar-assisted air-conditioning system installed in CIESOL building. *Renew Energy* 2009;34:1423–1431. [CrossRef]
- [37] Izquierdo M, González-Gil A, Palacios E. Solar-powered single-and double-effect directly air-cooled LiBr-H₂O absorption prototype built as a single unit. *Appl Energy* 2014;130:7–19. [CrossRef]
- [38] Li M, Xu C, Hassanien RHE, Xu Y, Zhuang B. Experimental investigation on the performance of a solar powered lithium bromide-water absorption cooling system. *Int J Refrig* 2016;71:46–59. [CrossRef]
- [39] Elzahzby AM, Kabeel AE, Bassuoni MM, Abdelgaied M. A mathematical model for predicting the performance of the solar energy assisted hybrid air conditioning system, with one-rotor six-stage rotary desiccant cooling system. *Energy Convers Manag* 2014;77:129–142. [CrossRef]
- [40] Dai YJ, Wang RZ, Xu YX. Study of a solar powered solid adsorption-desiccant cooling system used for grain storage. *Renew Energy* 2002;25:417–430. [CrossRef]
- [41] AKM - EAW Energieanlagenbau GmbH Westenfeld. Absorber AKM. Available at: <https://www.eaw-energieanlagenbau.de/absorber-akm.html>. Accessed October 29, 2021.
- [42] Yazaki Energy Systems, Inc. Water Fired Specifications. Available at: <http://yazakienergy.com/waterfiredspecifications.htm>. Accessed October 29, 2021.
- [43] Product catalogue A25s Solar Cooling systems. Available at: <http://www.purix.com/wp-content/uploads/2017/10/PURIX-Catalogue-A25s-EN.pdf> Accessed October 29, 2021.

- [44] Mugnier D, Sire R. SONNENKLIMA package solution description. 2009. Available at: <http://www.sol-arcombiplus.eu>. Accessed October 29, 2021.
- [45] 16LJ - 16LJ-F - Absorption chiller. Carrier heating, ventilation and air conditioning. Available at: <https://www.carrier.com/commercial/en/pl/products/air-conditioning/absorption-chillers/16lj-16lj-f/>. Accessed October 29, 2021.
- [46] AGO Congelo absorption chiller. Available at: <https://www.ago-energie.de/en/ago-thermal-technology/ago-congelo-absorption-chiller/>. Accessed October 29, 2021.
- [47] chillii® Cooling Kit WFCx [hot water fired] - Solar Next AG. Available at: <https://solarnext.de/en/product-list/chillii-cooling-kit-wfcx/?portfolioCats=199%2C201%2C200%2C202%2C256>. Accessed October 29, 2021.
- [48] chillii® Cooling Kit PSCx [hot water fired] - Solar Next AG. Available at: <https://solarnext.de/en/product-list/chillii-cooling-kit-pscx/?portfolioCats=199%2C201%2C200%2C202%2C256>. Accessed October 29, 2021.
- [49] Operating Instructions / Documentation PinkChiller PC19. Available at: https://eif-wiki.feit.uts.edu.au/_media/technical/renewables/pink_chiller_specs.pdf Accessed October 29, 2021.
- [50] Vapor absorption chiller | L5 Series. Available at: <https://www.thermaxglobal.com/tripple-effect-chiller-2-2-3-2-2/>. Accessed October 29, 2021.
- [51] Berdasco M, Vallès M, Coronas A. Thermodynamic analysis of an ammonia/water absorption-resorption refrigeration system. *Int J Refrig* 2019;103:51–60. [\[CrossRef\]](#)
- [52] Hussein AK. Applications of nanotechnology in renewable energies-A comprehensive overview and understanding. *Renew Sustain Energy Rev* 2015;42:460–476. [\[CrossRef\]](#)
- [53] Hussein AK. Applications of nanotechnology to improve the performance of solar collectors - Recent advances and overview. *Renew Sustain Energy Rev* 2016;62:767–792. [\[CrossRef\]](#)
- [54] Hussein AK, Walunj AA. Applications of nanotechnology to enhance the performance of the direct absorption solar collectors. *J Therm Eng* 2016;2:529–540. [\[CrossRef\]](#)
- [55] Otanicar TP, Golden JS. Comparative environmental and economic analysis of conventional and nanofluid solar hot water technologies. *Environ Sci Technol* 2009;43:6082–6087. [\[CrossRef\]](#)
- [56] Liu C, Wu Y, Li D, Ma T, Hussein AK, Zhou Y. Investigation of thermal and optical performance of a phase change material-filled double-glazing unit. *J Build Phys* 2018;42:99–119. [\[CrossRef\]](#)
- [57] Li D, Li Z, Zheng Y, Liu C, Hussein AK, Liu X. Thermal performance of a PCM-filled double-glazing unit with different thermophysical parameters of PCM. *Sol Energy* 2016;133:207–220. [\[CrossRef\]](#)
- [58] Han D, Meng Z, Wu D, Zhang C, Zhu H. Thermal properties of carbon black aqueous nanofluids for solar absorption. *Nanoscale Res Lett* 2011;6:1–7. [\[CrossRef\]](#)
- [59] Benabderrahmane A, Benazza A, Hussein AK. Heat transfer enhancement analysis of tube receiver for parabolic trough solar collector with central corrugated insert. *J Heat Transf* 2020;142. [\[CrossRef\]](#)
- [60] Rostami S, Sepehrirad M, Dezfulizadeh A, Hussein AK, Goldanlou AS, Shadloo MS. Exergy optimization of a solar collector in flat plate shape equipped with elliptical pipes filled with turbulent nanofluid flow: a study for thermal management. *Water* 2020;12:2294. [\[CrossRef\]](#)
- [61] Ghodbane M, Boumeddane B, Hussein AK. Performance analysis of a solar-driven ejector air conditioning system under EL-OUED climatic conditions, Algeria. *J Therm Eng* 2021;7:172–189. [\[CrossRef\]](#)
- [62] Hussein AK, Li D, Kolsi L, Kata S, Sahoo B. A Review of nano fluid role to improve the performance of the heat pipe solar collectors. *Energy Procedia* 2017;109:417–424. [\[CrossRef\]](#)
- [63] Nikbakhti R, Iranmanesh A. Potential application of a novel integrated adsorption-absorption refrigeration system powered with solar energy in Australia. *Appl Therm Eng* 2021;194:117114. [\[CrossRef\]](#)
- [64] Fitó J, Coronas A, Mauran S, Mazet N, Stitou D. Definition and performance simulations of a novel solar-driven hybrid absorption-thermochemical refrigeration system. *Energy Convers Manag* 2018;175:298–312. [\[CrossRef\]](#)
- [65] Al-Nimr MA, Mugdadi B. A hybrid absorption/thermo-electric cooling system driven by a concentrated photovoltaic/thermal unit. *Sustain Energy Technol Assess* 2020;40:100769. [\[CrossRef\]](#)
- [66] Xu Y, Li Z, Chen H, Lv S. Assessment and optimization of solar absorption-subcooled compression hybrid cooling system for cold storage. *Appl Therm Eng* 2020;180:115886. [\[CrossRef\]](#)
- [67] Jing Y, Li Z, Chen H, Lu S, Lv S. Exergoeconomic design criterion of solar absorption-subcooled compression hybrid cooling system based on the variable working conditions. *Energy Convers Manag* 2019;180:889–903. [\[CrossRef\]](#)
- [68] Arabkoohsar A, Sadi M. Technical comparison of different solar-powered absorption chiller designs for co-supply of heat and cold networks. *Energy Convers Manag* 2020;206:112343. [\[CrossRef\]](#)
- [69] Bellos E, Tzivanidis C, Symeou C, Antonopoulos KA. Energetic, exergetic and financial evaluation of a solar driven absorption chiller - A dynamic approach. *Energy Convers Manag* 2017;137:34–48. [\[CrossRef\]](#)
- [70] Bellos E, Tzivanidis C. Parametric analysis and optimization of a cooling system with ejector-absorption chiller powered by solar parabolic trough collectors. *Energy Convers Manag* 2018;168:329–342. [\[CrossRef\]](#)

-
- [71] Prasartkaew B, Kumar S. A low carbon cooling system using renewable energy resources and technologies. *Energy Build* 2010;42:1453-1462. [\[CrossRef\]](#)
- [72] International Institute of Refrigeration. 40th informatory note on refrigeration technologies. *Int Inst Refrig* 2020:17.
- [73] Vasta S, Palomba V, Frazzica A, Di Bella G, Freni A. Techno-economic analysis of solar cooling systems for residential buildings in Italy. *J Sol Energy Eng Trans ASME* 2016;138:1–11. [\[CrossRef\]](#)
- [74] Gabbriellini R, Castrataro P, Del Medico F. Performance and economic comparison of solar cooling configurations. *Energy Procedia* 2016;91:759–766. [\[CrossRef\]](#)
- [75] Eicker U, Pietruschka D, Haag M, Schmitt A. Energy and economic performance of solar cooling systems world wide. *Energy Procedia* 2014;57:2581–2589. [\[CrossRef\]](#)
- [76] Eicker U, Pietruschka D. Optimization and economics of solar cooling systems. *Adv Build Energy Res* 2009;3:45–81. [\[CrossRef\]](#)
- [77] Mahesh A, Kaushik SC. Solar adsorption cooling system: An overview. *J Renew Sustain Energy* 2012;4. [\[CrossRef\]](#)