



## Review Article

# Heat transfer enhancement using different types of turbulators on the heat exchangers

Hamdi Selçuk ÇELİK<sup>1,\*</sup>, L. Berrin ERBAY<sup>2</sup>

<sup>1</sup>Tuşaş Engine Industries Inc., Eskişehir, Turkey

<sup>2</sup>Department of Mechanical Engineering, Osmangazi University, Eskişehir, Turkey

## ARTICLE INFO

### Article history

Received: 14 April 2020

Accepted: 5 November 2020

### Key words:

Heat exchangers; Vortex generators; Baffles; Ribs; Perforation; Winglets

## ABSTRACT

Energy-saving and heat transfer enhancement considerations are more crucial due to nearly running out energy resources and ensuring the sustainability of nature. The heat exchangers are one of the main components and directly affect the thermal efficiency of the systems. To enhance the heat transfer rate, the fin and plate structure is widely used. Various vortex generators may be involved generally on the surface of fins, like ribs, baffles, delta winglets, and perforations. Turbulators make the heat transfer performance better significantly but increase the friction of the fluid on the contacting surfaces and cause the pressure drop-down which depends on thermal properties of the fluid characteristics. This paper presents general protrusion vortex generators overview to heat transfer augmentation with pressure loss as an extensive literature review. The correlations are derived in terms of some parameters of turbulators like; angle, pitch, shape and combinations of an array. The target of this study is consolidating the verified outputs of the literature and support the increasing thermal performance of the heat exchangers. In conclusion, two tables are made for the first time and summarizing the crucial features of solid, perforated baffles/blockages and winglet turbulators, mentioned in the literature are presented. Obstacles such as winglets and vortex generators are used commonly to increase the heat transfer rate per unit volume for finned to tube exchangers with various types. In order to augment the heat transfer, the design parameters of important consideration are attack of angles, height and array structure in both laminar and turbulated fluid characteristics. Involving perforation forms on the surface may be used for winglets with variable angles both decrease the pressure loss and increase the heat transfer performance.

**Cite this article as:** Çelik HS, Erbay LB. Heat transfer enhancement using different types of turbulators on the heat exchangers. J Ther Eng 2021;7(7):1654–1670.

## INTRODUCTION

In recent years, the energy consumption rate has been increasing with the population growth of the people, even limited resources like fossil fuels and the other related

resources. This energy resources require so big time for the generating and consolidation with nature cycle. Renewable energy utilisation is so common because of having sustainability and may be transformed into different types of

### \*Corresponding author.

\*E-mail address: hamdiselcuk.celik@tei.com.tr, lberbay@ogu.edu.tr

This paper was recommended for publication in revised form by Regional Editor Muslum Arici



energy. Heat transfer is the fundamental energy transfer which is mainly familiar nearly all of the HVAC systems. In order to transfer to heat, the heat exchangers are used and main components which directly affects the efficiency of the systems. The enhancement heat transfer convection performance of the heat exchangers; cause to consume fewer energy resources. The fin and tube and plate to plate heat exchangers are mainly used for the HVAC systems, the fin pitch, angle, pipe construction, sequence are the geometrical parameters that directly affect the heat transfer rate. For the aim of both keeping the heat transfer area of the exchangers constant and increasing the heat transfer performance; turbulators in the form of ribs, baffles, delta winglets, louvered and perforated wide variety constructions are used as well on the fin surfaces of the heat exchangers. But the pressure drop down is so significant which is increased, depends on the turbulator types and characteristics of the flow.

In this paper, different protrusion types of vortex generators on the plate a fin surface of the heat exchangers have been reviewed on the literature and classified based on the heat exchanger and rib types, fluids arrangement, pitch, angled, Reynolds number (Re) range which defines the fluid characteristics and correlations which are derived for Nusselt number (Nu) and friction factor (f). The parameters of the vortex generators were determined, by numerical analyses accordingly, the results were compared concerning the heat transfer enhancement and pressure loss. Moreover, some of the experimental efforts were supported developing the methods of heat exchanger in the purpose of validating like air tunnel and parameters.

Compact heat exchangers have been used commonly, due to their compact volume via big heat transfer area by their fins and prominent forms. Many engineering applications had held benefit attention to develop the heat transfer rate of the compact heat exchangers in gas–gas and gas-liquid side. For the gas, it is well known that the thermal conductivity of the gas is lower than liquid one which needs to improve its convective heat transfer coefficient. The traditional heat exchangers are generally improved by present enhancement techniques with concentration on many types of surface augmentation. The augmentation of heat transfer can be done by shivering the boundary layer growth, increasing the turbulence volume, and generating secondary flows. By this way, desired heat transfer performance may be provided with low-cost materials of the heat exchangers. [1,2].

Turbulators which are used on the plate or fins of the heat exchangers are classified as solid ribs, blocks and baffles, perforated ribs blocks and baffles and vortex generators, winglets. Turbulators are also used inlet surface of pipes with liquid fluid, which is distinguished as swirling and non-swirling types additionally in the purpose of increasing the heat transfer performance of the heat exchangers. But; generally utilising the vortex generators on the fin surfaces of heat exchangers with gas is more common as described

because of having lower thermal conductivity. These heat exchangers are numerically analysed by commercial softwares and experimental analyses have been performed in the air tunnels from the literature. The turbulators which are used in air ducts; have been classified as ribs, blocks and baffles and obstacle types. The ribs, block and baffles are classified as solid and perforated. Obstacle types contain winglets, vortex generators, rings and tapes. Moreover, winglets are mainly used as rectangular, trapezoidal and delta winglets. [3]

## SOLID RIBS, BLOCKS AND BAFFLES

These turbulators are used particularly on the plate surfaces which direct the gas fluid. Turbulator forms are located as angled, transverse and ribs with different shapes. Design parameters are input as height, pitch ratio, rib angles and shapes. The affection of these parameters is directly related to heat transfer coefficients and local Nusselt number distribution. Furthermore, pressure drop down on the gas fluid which is coming from turbulators is a crucial result and criteria that affect the performance of vortex generators significantly.

Liou, Chang and Chan [4] researched the affection of involving the system, louvered turbulators as baffled ribs on thermal performance factor. The parameters are defined as variable pitch/ hydraulic diameter (p/e). After numerical analysis, the best heat transfer performance is provided when the Reynolds number is ranging between 5.000–20.000 with 3–4 louvered baffles when the friction factor is considered. The pitch/hydraulic diameter is 1 and correlations are derived between Nusselt and friction factor for different scenarios.

Promvongse and Skullong [5], made an experimental study about involving the plate heat exchanger V-grooved and V-chamfered ribs 45° and - 45° angled turbulators while the range of the Reynolds number is from 5.300 to 23.000. V-ribs are classified about V-down and V-up related to a direction for both grooved and chamfered ribs. In conclusion, correlations are derived between Nusselt number and friction factors for each scenario. The combined punched-V-rib and chamfered-V-groove provide the augmentation of thermal performance at about 14–15% higher than the combined solid-V-rib and higher from chamfered-V-groove about 56–77% above the groove alone. The friction factor is defined as the relation with Nusselt by graphical indications. The combined turbulators with V-up arrangement are recommended because they have an advantage of thermal performance over the ones with V-down. The maximum thermal efficiency factor (TEF) is 2.47 is found for the combined V-up punched-V-rib and chamfered-V-groove at 45° and when the Nusselt is increased about 6.52 times, friction factor is enhanced about 38.67 times above the smooth duct alone. In Figure 1, the geometry of the ribs are indicated and the combined scenario is also available.

The geometrical parameters related to the ranges also shown in Table 1.

Han and Park [6,7], overviewed the effects of angle for the channel aspect on heat transfer performance and friction factor with Reynolds (Re) range from 10.000–60.000. The best heat transfer and pressure drop down were found at 60° angled with the aspect ratio of the channel 2.

Zhang et al. [8], made a study for the heat transfer enhancement due to integration of longitudinal vortex

generators (LVG) by three-dimensional steady numerical analysis. The parameters were defined as transverse spacing, the height of micro gaps and number of turbulator pairs. It was detected that the micro gaps larger heights do not cause the remarkable enhancement on the heat transfer rate, but have much lower pressure drop, between Reynolds range 100 to 700 and the interactions between the vortices induced by LVGs leads to increase in the pressure drop penalty. In Figure 2, the geometry of the LVGs is indicated. The heights of the micro gaps are compared to performance parameters.

Lau et al. [9], analysed experimentally, the effects of angle on the straight and V-shaped ribs in a square channel. The straight ribs have 90°, 60° and 45° angled. V-shaped ribs are angled 60° and 135° well as crossed ribs 60°/ 120° were tested that is shown in Figure 3. The best heat transfer performance and pressure drop down was observed 60° V-shaped ribs.

Wang and Sunden [10], made an experimental study in a rectangular channel which they involved various-shaped ribs pointing upstream to investigate heat transfer and friction characteristics. The ribs are oriented transversely to the mainstream in the periodic arrangement. The ratio of rib height-to-duct and hydraulic diameter is fixed as 0,1 and the rib pitch-to- height ratio is varied 8 to 15. The Reynolds number is ranging from 8.000 to 20.000. The analyses are concluded trapezoidal-shaped broken ribs with decreasing height which is in the flow direction has the best heat

**Table 1.** Geometrical Parameters of with Ranges [5]

Parameters	Range
Aspect ratio (AR=W/H)	8
Rib height (b)	12 mm (fixed)
Rib blockage ratio	0.5 (fixed)
The hole diameter of V-rib	5 mm (fixed)
Rib attack angle	45° (fixed)
Hole inclination	45°, 0° and -45°
Groove attack angle	45° (fixed)
Relative rib pitch ratio ( $R_p$ )	1.0, 1.5 and 2.0
Relative groove pitch ratio ( $R_p$ )	1.0, 1.5 and 2.0
Groove position to rib pitch ratio	0.5 (fixed)
Depth of groove	5 mm (fixed)
Chamfer angle of the groove	45° (fixed)

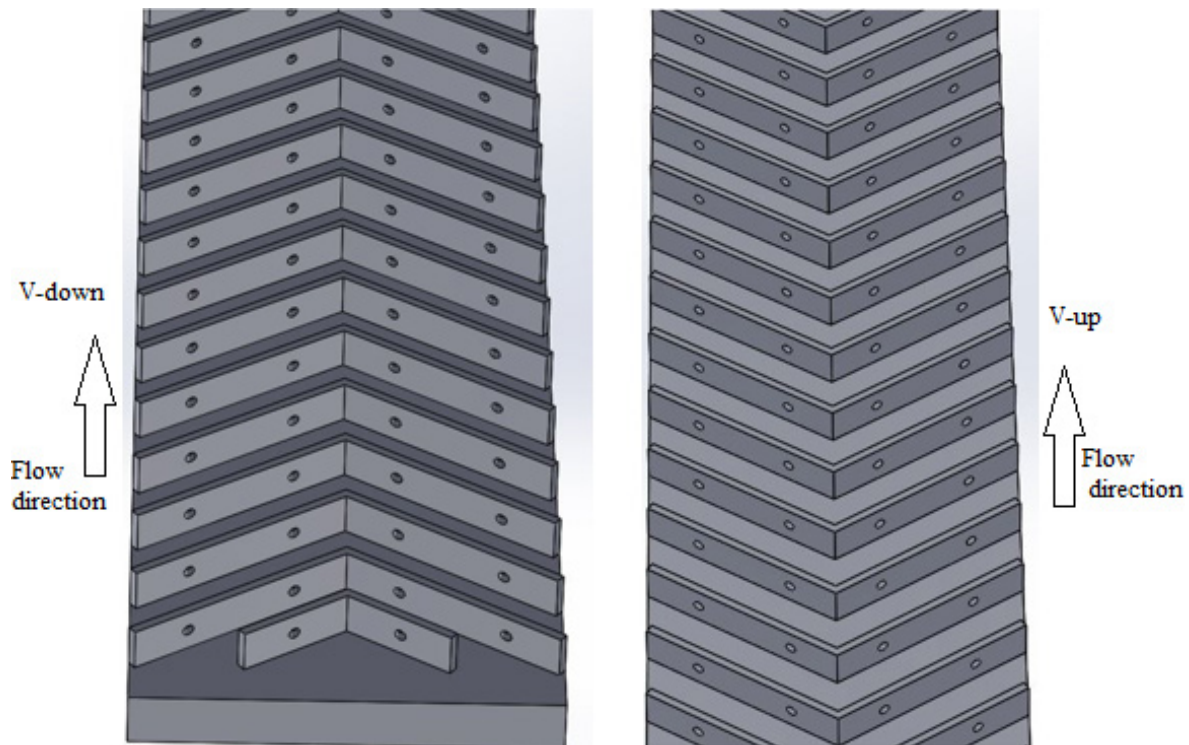

**Figure 1.** The absorber with combined V-ribs (modified from [5]).

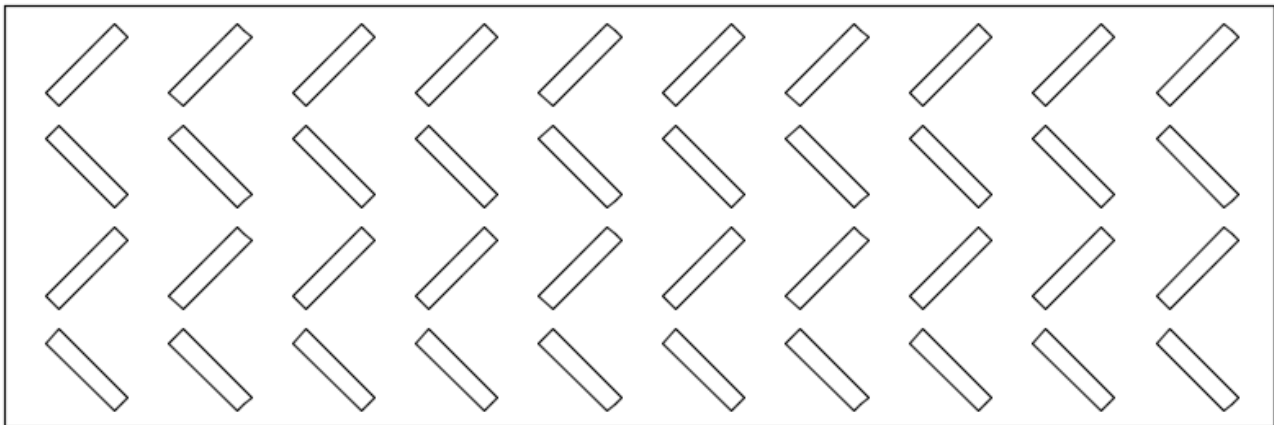

Figure 2. Arrangement of LVG array and geometric parameters (modified from [8]).

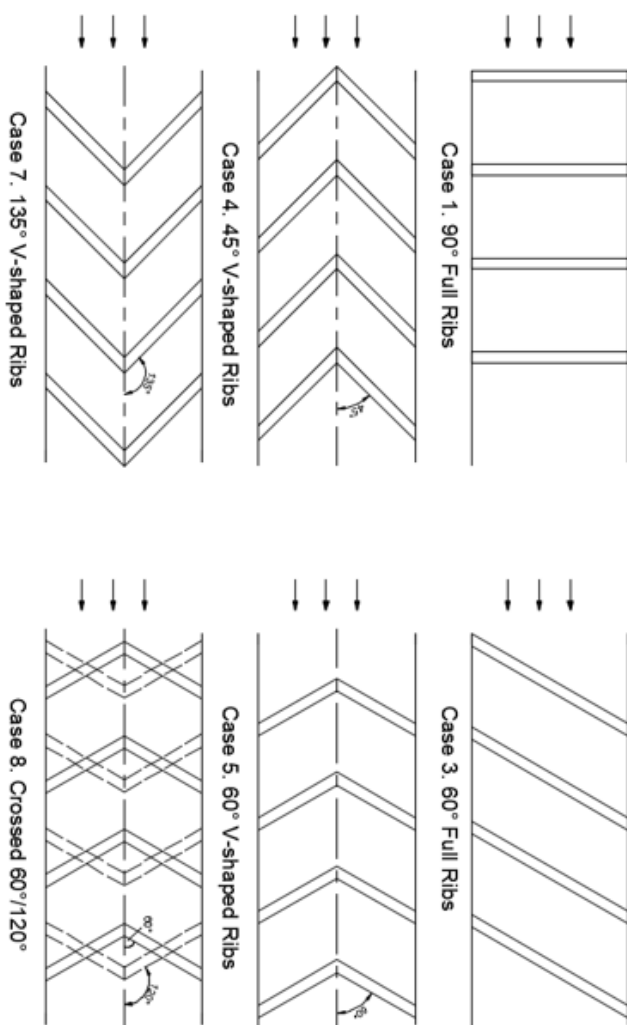

Figure 3. Different ribs geometry configurations (modified from [9]).

transfer performance. This scenario suppresses the local hot spot as well which occurs in the region of behind the ribs.

Han and Zhang [11], investigated effects of broken rib involvement which was experimented about the heat transfer performance and pressure loss in a square channel. The Reynolds number is ranging from 15.000 to 90.000. Twelve configurations were created as 90° broken / continuous rib, 60° /45° parallel broken rib, 60° /45° V-shaped rib, 60° /45° parallel broken rib, 45° parallel continuous rib, 60° /45° parallel continuous rib. It was concluded that 60° parallel broken ribs have the 2–3 times higher heat transfer enhancement than 45° V-shaped broken rib and 60° V-shaped continuous rib but increase pressure drop penalty 7–8 times. The configurations are indicated in Figure 4.

Promvong and Thianpong [12], investigated as well the different shaped ribs (triangular or isosceles, wedge-shaped or right-angled triangular and rectangular) on heat transfer and friction loss behaviour in a rectangular channel for Reynolds number between 4.000 to 16.000. In conclusion, triangular ribs have better heat transfer performance than rectangular shapes after the experimental analysis. The different shapes are shown in Figure 5.

Li et al. [13], made a parametric study on heat transfer and flow characteristics in rectangular channels with strip slits in ribs on one wall. Slitted ribs on the turbulent flow and heat transfer characteristics are explored in rectangular cooling channels which have an aspect ratio of 4:1. Reynolds number ( $Re$ ) is ranging from 20.000 to 80.000. The various ratios of slit-length-to-rib-length ( $R_1=0, 0.20, 0.35, 0.50$ ) and rib heights ( $e=10\text{ mm}, 15\text{ mm}$  and  $20\text{ mm}$ ) are compared by numerical analyses. It is found that strip slit in low height ribs has both lower Nusselt number and friction factors than solid ribs. The investigation results suggest that introducing a short-length strip slit in ribs could be beneficial to increase heat transfer performance of cooling channels which have particularly high height ribs. The channel and rib geometry is indicated in Figure 6.

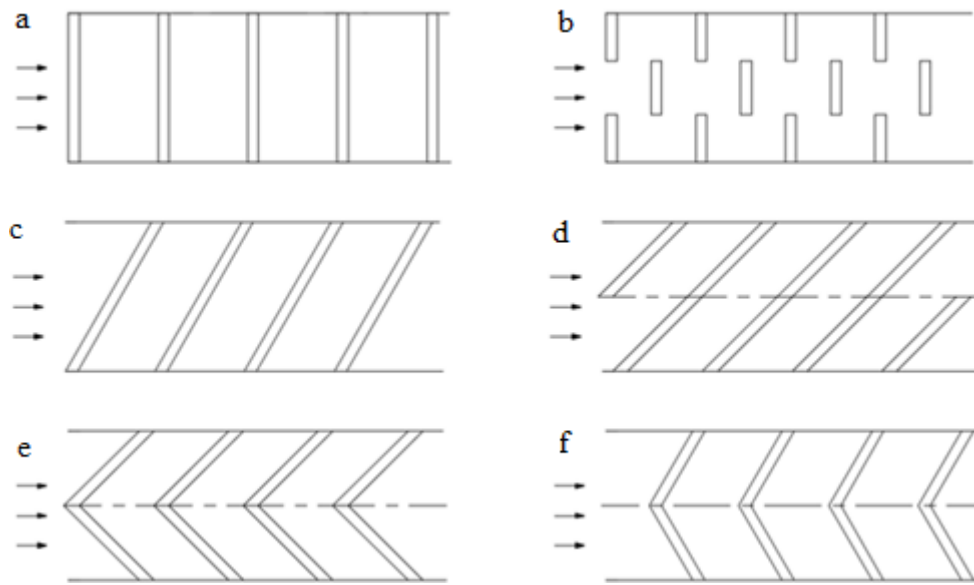

**Figure 4.** Continuous and broken rib configurations (a) 90° continuous rib, (b) 90° broken rib, (c) 60° parallel continuous rib, (d) 45° parallel continuous rib, (e) 45° V-shaped continuous rib, (f) 60° V-shaped continuous rib (modified from [11]).

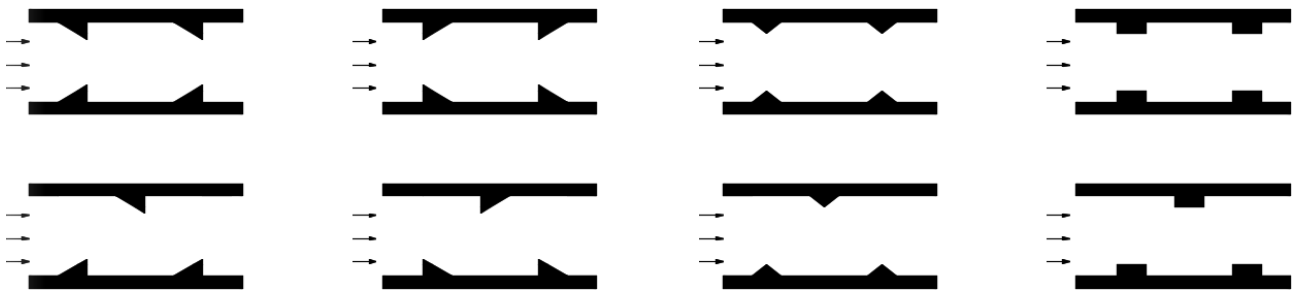

**Figure 5.** Different staggered ribs (modified from [12]).

Salhi et al. [14] made a numerical investigation study to examine heat transfer performance affection the inclination angle of the involved baffles in a two-dimensional horizontal channel. The baffles are mounted on lower and upper walls of the channel and inclination angles are 40°, 55° and 65°. The walls have a constant temperature as 375 K and the Reynolds number is about 87300. Consequently, the best heat transfer performance is found when the angles of baffles are 65°. The distribution of local friction coefficient is also affected positively when the inclination angle is increased. The physical model is shown in Figure 7.

#### Perforated Solid Ribs, Blocks and Baffles

The solid ribs are used with a wide variety of constructions. They increase the heat transfer rate properly, But also, pressure drop down should be considered to avoid usage of more powered circulators for the heat exchangers. Therefore perforated forms are added generally on the ribs blocks, baffles and louvered surfaces. This is made with regular array and pressure drop-down is reduced. This

means perforated forms are involved with different shapes of winglets.

Sara et al. [15], made a study to understand perforation effects on heat transfer in a channel which has a flat surface and involved solid and perforated rectangular blocks. The tests are performed experimentally and due to the understand perforation effect, and it is seen the heat transfer performance is increased about 20%. Consequently, this augmentation depends on the diameter of the holes as a design parameter. The range of Reynolds number is about 6.670–40.000.

Hwang and Liou [16], determined the affection of perforated forms involvement on heat transfer performance and friction factor in an experimental channel. The Reynolds number range is from 10.000 to 50.000 rib pitch/height ratio is defined from 5 to 20. The conclusion emphasizes that using perforation involvement provides the hot-spot elimination from the surfaces of the ribs.

Moon and Lau [17], studied the blocking flow in the rectangular channel between two holes. Experiments are

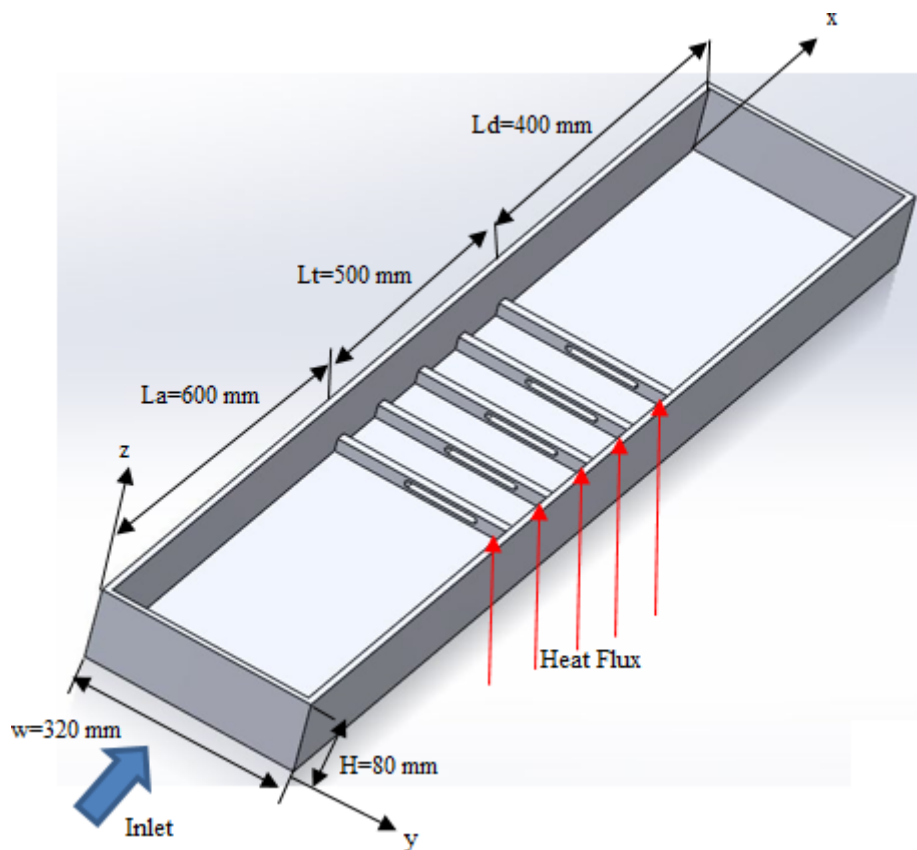

**Figure 6.** The rectangular channel with an array of slit ribs on the bottom of the heated section. The slit ribs have different rib height ( $e= 10 \text{ mm}$ ,  $15 \text{ mm}$  and  $20 \text{ mm}$ ) and slit length ( $L_s/L_r = 0, 0.20, 0.35, 0.50$ ) (modified from [13]).

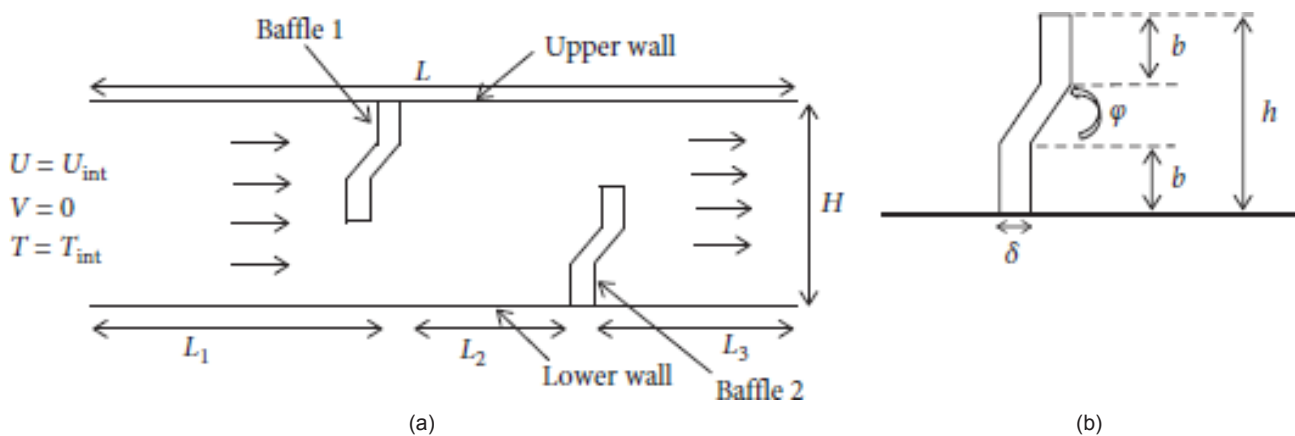

**Figure 7.** a. The physical model in  $x,y$  plane, b. Baffle dimensions ( $\varphi$ : inclination angle) [14].

conducted to steady-state heat transfer between two blockages with holes and pressure drop across the blockages. The Reynolds number is ranging from 10,000 to 30,000 for nine different staggered arrays of holes. By using blocking, the heat transfer augmentation is measured between 4.6–8.1 times more. The heat transfer enhancement is measured lower for higher Reynolds numbers. It is also found that

smaller holes in the blockages cause higher heat transfer performance than larger holes. Larger holes cause higher pressure loss and require pumping power more. The local heat transfer distribution is dependent obviously on the configurations of the hole arrays.

Bucnhlin [18], made a study about different shaped holes effects on heat transfer performance and pressure loss

and compared the differences. The best scenario is chosen as pitch ratio equals 5 with open area ratio is 0.53 for the channel. Reynolds number is ranging from 30.000 to 60.000. The different scenarios have been indicated in Figure 8.

Shin and Kwak [19], made a study about the affection of hole construction on friction factor and heat transfer performance, all the scenarios have the same surface area, and after the experimental analysis; wide holes scenario has the best heat transfer performance. The Reynolds number is ranging from 20.000 to 40.000. In Figure 9, the configurations of the holes are shown.

Zheng et al. [20], made a study about reviewing multi longitudinal vortices in the tubes of heat exchangers. The aim is analysing synergy between friction factor and heat transfer performance. In conclusion, forms of many vortex generators suffer from pressure loss and using longitudinal vortices with perforated forms improve the synergy between, the heat transfer rate and pressure loss.

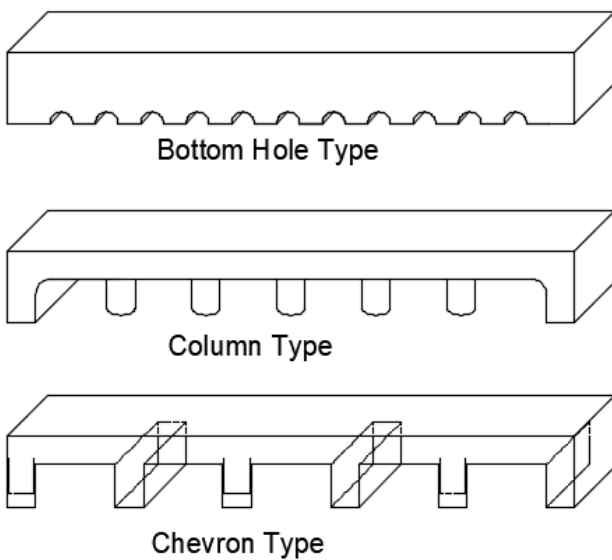

Figure 8. Schematic of perforated ribs (modified from [18]).

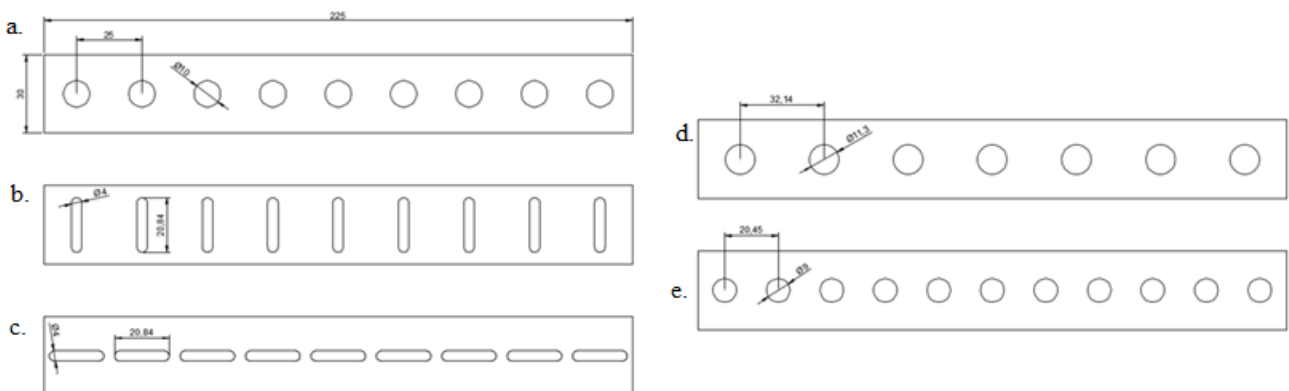

Figure 9. Hole configurations (a) circular holes (b) narrow holes (c) wide holes (d) circular 7 holes and (e) circular 11 holes (modified from [19]).

Skullong et al. [21], made an experimental study about involvement of a turbulator inlet surface of the round tube with variable design parameters like winglet blockage ratio, and pitch ratio; under same conditions, perforated (WPT) and non-perforated (WTT) winglet effects on the performance were determined Reynolds number is ranging from 4.180 to 26.000. Even though, WTT scenarios heat transfer performance is higher about 1.2 times and the pressure drop down of WPT is about 3 times lower than WTT. This indicated the friction factor is optimized by perforated forms.

Karwa et al. [22], made an experimental investigation about the affection of using perforated baffles in a rectangular air duct for a range of Reynolds number from 2.850 to 11.500. Nusselt number is increased about 82.7% for the best scenario, but the friction factor is 11.1 times bigger than a smooth tube when perforated forms are involved on the surface of turbulator, a significant decrease has happened on the friction factor.

Karwa and Maheshwari [23], made an experimental study about finding out the effects of perforation on the heat transfer performance and friction factor while Reynolds number is ranging from 2.700 to 11.150. Maximum augmentation on Nusselt number for fully and half-perforated baffles were found respectively 169% and 274%. But half perforated baffles cause about 4 times lower friction than a solid one. This shows perforated forms are more usable when the pressure drop down is considered.

**Obstacles; Winglets, Vortex Generators Rings, Tapes**

Obstacle forms are mainly used for heat exchangers on the surface of fins with finned tube heat exchangers particularly, the implementation and creation of these forms are more common for the heat exchangers, Winglets are preferred more for wide variety sectors of the heat exchangers. Therefore, different scenarios are created and compared with each other.

Manjunath et al. [24] made a study involving the spherical vortex generators on the absorber plate and analysing

affection of this vortex generators on the heat transfer performance and pressure loss which the diameter ( $D$ ) is changed as 5, 10, 15, 20, 25 and pitch ( $P$ ) affection is involved with changing ratio of  $P/D$  as 3,6,12. The Reynolds number is ranging from 4.000 to 25.000 based on numerical and experimental analysis results; In conclusion; the best results are provided when diameter ( $D$ ): 25, pitch / diameter ( $P/D$ ):3 and Reynolds number for the best scenario is 23.560. The heat transfer performance is enhanced about 2.52 times even pressure loss is increased 13.4 times compared with the scenario that hasn't any spherical vortex generators on the surface. The plate with a spherical vortex generator is indicated in Figure 10.

Kotcioglu et al. [25] investigated the second law of a cross-flow heat exchanger duct which have winglets that are based on entropy generation, The analysis was performed by experimental method. It was found out that increasing the velocity of the fluid, the heat transfer rate is enhanced but reduces the heat transfer irreversibility. The mass flow is ranging from 11 to 23 kg/s. and entropy generation is controlled by the angle of the winglets and velocity of the fluid. The geometry of the rectangular channel with winglets are shown in Figure 11.

Wu and Tao [26], studied effects involving the system adding straight winglets which design parameters are defined as angles  $15^\circ$   $30^\circ$   $45^\circ$  and  $60^\circ$  in the air duct, Reynolds number is ranging from 800 to 3.000. After the numerical analyses;  $45^\circ$  angle is the best to have higher heat transfer performance, but the pressure drop down is more about 2.3 times.

Zhou and Ye [27], investigated the thermohydraulic performance of curved trapezoidal winglet. The design

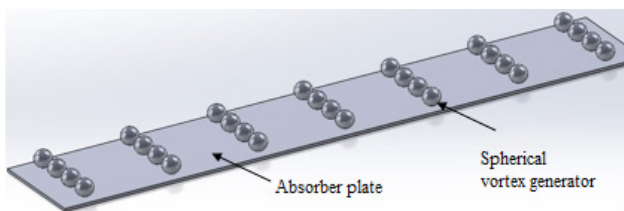

Figure 10. The plate with spherical vortex generator (modified from [24]).

alternatives are trapezoidal, rectangular and delta winglets. The performance comparison on the heat transfer was realized when the Reynolds number is ranging from 3.000 to 27.000. Considering the turbulence model, delta winglet and trapezoidal winglet has the best performance, for the laminar and transitional flow region, delta winglet heat transfer performance is higher than trapezoidal one under turbulent flow regions. The winglets are indicated in Figure 12.

Gentry et al. [28], augmented average heat transfer 50%–60% for flow over a plate at laminar flow regions, using delta-wing vortex generators, Optimal delta-wing is used Reynolds numbers of 600, 800 and 1000 which is nearly same with air conditioner and refrigerators based on wing-chord length. The results make interactions clearer between the vortex and boundary layer. High circulation vortex thins the boundary layer when it is located near the edge of it.

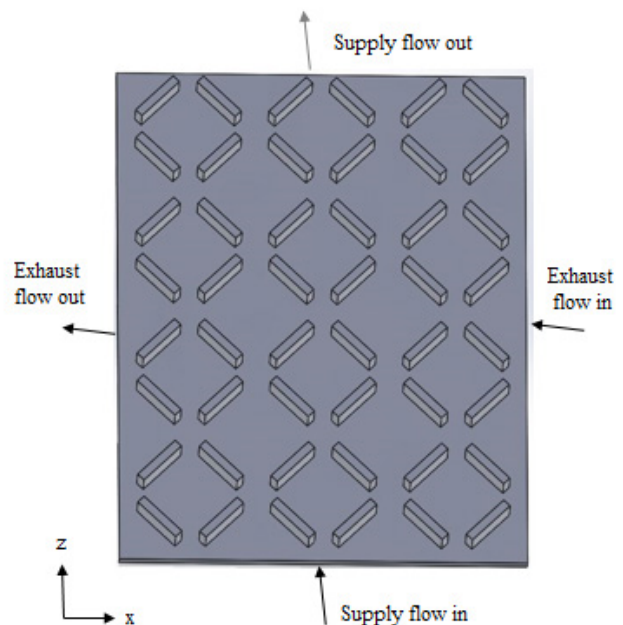

Figure 11. Crossflow heat exchanger with winglets (modified from [25]).

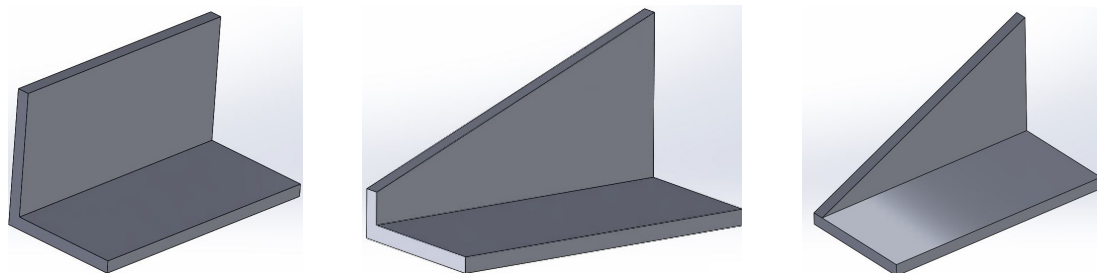

Figure 12. Rectangular, Trapezoidal and Delta winglets (modified from [27]).



Promvonge et al. [29], studied by the experimental method, the effects of combined ribs delta winglet (DW) type vortex generators under turbulent flow region through air heater duct. Ten pairs of the DWs having roughness height 0.4 were tested with transverse pitch ratio is 1 and three angles of winglet as  $60^\circ$ ,  $45^\circ$  and  $30^\circ$  performed. The Reynolds number is ranging from 5.000 to 22.000. Consequently; Nusselt number and friction factor are much higher with first single status with  $60^\circ$  delta winglet angles.

Wu and Tao [30] investigated delta winglets affection which is placed on the surface of the plate in air tunnel and design parameters are defined with the angle of delta winglets are changed as  $15^\circ$ ,  $30^\circ$ ,  $45^\circ$  and  $60^\circ$  and effects are evaluated on heat transfer performance. The analyses are made by both numerical and experimental solutions and Reynolds number is ranging from 500 to 2000. Consequently, the experimental results are agreed with numerical results and  $60^\circ$  angled delta winglet has the highest heat transfer performance, the geometry in air tunnel and graphical data is indicated in Figure 13.

Chu et al. [31], made a study about performance parameters of fin and oval tube heat exchanger under the synergy principle with delta winglets and angle of attack between fin and row numbers. Reynolds number is ranging from 500 to 2500. Numerical analyses are validated by proven designs in the literature. Consequently, when the angle of attack is lower, the heat transfer performance is better but the friction factor increased too high. By the best scenario elliptical pipe and  $90^\circ$  fin angle of attack, by using the longitudinal vortex generators, While the heat transfer performance is increased about 13.6–32.9% the friction factor is increased 29.2–40.6%. This means involving the winglets on the fin surface effects the performance significantly and alternative winglet types should be analysed by synergy principle.

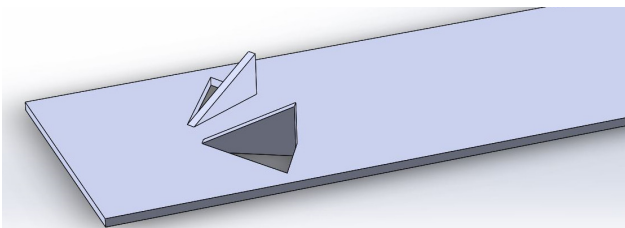

Figure 13. Tested plate in the air tunnel (modified from [30]).

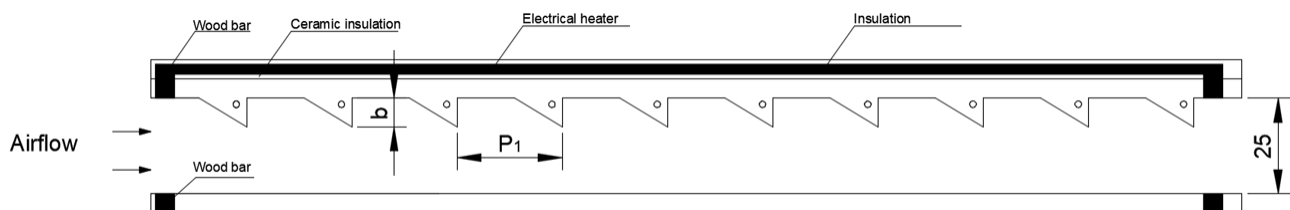

Figure 14. Test section mounted with PWs (modified from [32]).

Promvonge and Skullong [32] made an experimental study to compare heat transfer enhancement and friction loss performance of punched delta winglets (P-DW) and punched elliptical winglets (P-EW) that are mounted on the upper duct wall with four punched hole sizes are tested at a fixed attack angle, optimum relative pitch and height. The Reynolds number ( $Re$ ) is ranging from 4100 to 25500. After tests are performed, they find out punched delta winglets (P-DW) presents higher thermal performance enhancement factor ( $\eta$ ) than elliptical delta winglets (E-DW). Under the same conditions, solid delta winglets (DW) and solid elliptical winglets (EW) are included for comparison. Even though the solid DW and EW have the highest heat transfer enhancement and friction loss, PWs present better than the solid ones. P-DW with smaller hole size has the best heat transfer and friction loss around 5.7 and 40 times over the smooth duct. The optimum thermal performance enhancement factor ( $\eta$ ) is found as 2.17 with certain hole size. The analyses are concluded that the PWs provide about 5–8% higher thermal performance enhancement factor ( $\eta$ ) than solid winglets. The compared geometries are indicated in Figure 14.

## REVIEW RESULTS

As defined with comparing the various protrusion turbulator alternatives; like solid and perforated ribs and obstacles; like winglets; have been used within the purpose of enhancing the thermal performance of the heat exchangers. This is normal to confront with pressure drop down due to involving turbulators in the system. Many investigations have been compiled to minimize pressure loss as a motivation. The concepts are related to design parameters and boundary conditions of the heat exchangers. Therefore, all of the determined studies are consolidated about their parameters and conditions to present comprehensive understanding on the performance of all types taken place in the literature, two tables were prepared and presented with parameters and analysis methods. In table 2, important features of solid and perforated baffles, blockages are indicated, In table 3, important features of winglet and obstacle turbulators are shown respectively. These tables are going to be helpful for designers and especially for newcomers. The reviewed researchers have verified their results

with literature literature and derived the correlations with deviations. This approach makes the comparison results more certain.

Furthermore, the protrusion type of the turbulators, may be modified as dimple type with identical design and compared with each other under the same conditions. By this way, researchers will have the performance parameters both protrusion and dimple turbulator types. Effect of roughness on the walls of turbulators is a critical parameter which should be considered for comparison studies. Besides, in the literature various nanofluid additives are used and combined with turbulators, this makes the heat transfer performance so higher than only turbulator involvement. The cost and producibility of the heat exchangers should be considered which is coming from involving the system various turbulators and nanofluids.

## FUTURE WORKS

Turbulators are mainly used to increase the thermal performance of the heat exchangers. But this comes up with pressure drop down increment on the system. The researchers have been focusing the different constructions and forms to minimize it. Even though geometrical parameters of the heat exchanger and turbulator design are changed, producibility and cost of the systems are considered. In the future, the design alternatives will be more than now as a result of more powered production methods and capability.

Moreover, numerical analysis methods will be extended and used commonly more than now. By this way, the results will have less deviation and agree more with experimental solutions. Day by day the energy resources have been running out and more expensive, the wider variety of the materials and nanofluid additives may be shown in the heat exchangers as a result of developments on the metallurgy and thermophysical features of the fluids.

In the literature, some researches may be examined which is convenient to use with compact heat exchangers, an experimental study was performed with liquid metal mixture including gallium, indium and tin (Ga-In-Sn), the thermo-hydraulic evaluation parameter was augmented to 1.3 [33].

Nitrogen-doped, graphene-based on nanofluids are used in a counter-flow double-pipe heat exchanger and the heat transfer coefficient was nearly increased 16.2% [34]. Furthermore, in another study, the influence of different functional covalent groups on the thermophysical properties of carbon nanotube-base fluid was experimentally investigated at first and cysteine (Cys) and silver (Ag) were covalently attached to the surface of the multi-walled carbon nanotubes (MWCNT). When the heat transfer performance is enhanced by selecting MWCTN/water as the working fluid, the pressure loss is reduced with involvement of the nanofluids in the corrugated plate heat exchanger.

[35]. Moreover, nano-particulate graphene-water /ethylene glycol (WEG 60:40) is used in a compact heat exchanger and the affect on thermal performance with friction factor is evaluated. The thermal performance evaluation criteria of the system is increased about 21% despite 12.1% enhancement is found on the pressure drop value [36].

In conclusion the passive techniques adding nano-particles, vibrators etc. is crucial and are going to be preferred in the various heat exchangers more in the future in order to increase the heat transfer performance.

## CONCLUSIONS

An overview has been performed for a comprehensive review of heat transfer performance and friction characteristics of heat exchangers which shape roughened ducts and finned tube provided with various turbulators.

- Particularly, solid and perforated ribs are determined and obstacle turbulator commonly winglet types are investigated in the literature. It is found that perforated ribs are more efficient than solid ribs because perforation in ribs/blocks/ baffles enhances the heat transfer by the elimination of hot spots behind the ribs and baffles. The shape of holes and angle of perforation are the main parameters which affect the heat transfer and friction characteristics of the ducts. These type of turbulators are generally used for solar air heaters.
- Turbulators which are designed as obstacles; winglets and vortex generators are commonly used to enhance the heat transfer performance to cause turbulence, but design parameters are so crucial for the reduce to the pressure drop down, winglet types, angles of the attack, height and pitches are design parameters for the winglets.
- Involving perforation forms on the surface may be used for winglets with variable angles both decrease the pressure loss and increase heat transfer performance.
- Between delta, trapezoidal and rectangular winglet constructions, trapezoidal winglet is the best under laminar and transition flow regions. But when the flow region is converted turbulent characteristics, delta winglets are the best about heat transfer performance between winglets.
- The design parameters are so crucial to increase the performance as well according to boundary conditions. Protrusion from heat transfer surfaces like winglets and vortex generators have crucial roles to increase heat transfer performance and make the heat exchanger heat transfer area smaller to volume. Therefore, many shaped winglets are convenient for using in the recuperators.

Table 2. Summary of crucial features of solid and perforated baffles/blockages used by various investigators

No	Type of ribs, structure and (Analysis method)	Investigators	Reynolds Number (Re)	Aspect ratio (W/H)	Relative roughness height (e/Dh)	Relative roughness pitch (p/e)	Perforation angle (β)	Derived Correlations	Remarks
1	Solid and perforated punched-V-rib and chamfered V-groove (Experimental analysis)	Promvonge and Thianpong [5]	4000–16000	8	0,2	-	45°, -45°	$Nu = 0.252Re^{0.652}Pr^{0.4}(Rp)^{0.467}$ (Deviation: ±6,7%) $f = 3.014Re^{0.248}(Rp)^{1.232}$ (Deviation: ±8%)	V-groove alone and V-up condition; 45° perforation has increased the performance.
2	Solid longitudinal V ribs with micro gaps on solar collector (Numerical analysis)	Zhang, Joshi and Tao [8]	100–700	4	0,081	10	45°	-	Larger heights do not cause the remarkable enhancement in heat transfer rate but have much lower pressure drop.
3	Solid parallel and broken V-shaped ribs (Experimental analysis)	Han and Zhang [11]	15000–90000	20	0,0625	10	45°60°, and 90°	-	60° parallel broken ribs have the 2–3 times higher heat transfer enhancement but 7–8 times friction increment than non-turbulated scenario.
4	Solid triangular and rectangular shaped ribs (Experimental analysis)	Promvonge and Thianpong [12]	4000–16000	15	0,3	6,6	0°	-	Triangular ribs have better heat transfer performance than rectangular shapes.
5	Perforated block attached to one wall (Experimental analysis)	Sara et al. [15]	6670–40000	2	0,081	0,309 - 1,407	0°	$Nu/Nu_s = 19.586Re^{-0.186}(S/D)^{0.05}(D/D)^{0.09}\beta^{0.10}(1/\cos\theta)^{0.17}$ (Deviation: ±5,33%)	$Nu/Nu_s = 0.8-1.0$ for solid and $1.0-4.4$ for perforated $f/f_s = 0.7-0.9$ for solid and $0.3-0.8$ for perforated.

(continues)

Table 2. Continued

No	Type of ribs, structure and (Analysis method)	Investigators	Reynolds Number (Re)	Aspect ratio (W/H)	Relative roughness height (e/Dh)	Relative roughness pitch (p/e)	Perforation angle (β)	Derived Correlations	Remarks
6	Solid and perforated ribs on two opposite walls in staggered fashion (Experimental analysis)	Hwang and Liou [16]	10000–50000	4	0,081 and 0,162	5,10,15 and 20	0°	$Re=3,31(PR/10)^{0,53}$ for solid rib $G=3,72H^{0,35}(PR/10)^{0,08}$ for solid rib $ribRe=5,15(PR/10)^{0,53}$ for perforated rib $ribG=2,25H^{0,35}(PR/10)^{0,08}$ for perforated rib	$Nu/Nu_s=1,0-1,55$ for solid and 1,15 for perforated $f/f_s=6-9$ for solid and 4–6 for perforated. Deviation is between 6–8% for whole equations.
7	Perforation in middle, above midplane and below midplane in blockage of duct size. (Experimental analysis)	Moon and Lau [17]	20000–30000	5,84	1	p=63,5 and l=19,1 mm - 76,2 mm	0°	-	$Nu=155,79 - 244,75, f=5,34-42,79$ for the $Re=2 \times 10^4$ $Nu=320,08-501,39$ $f=5,08-47,26$ for $Re=3 \times 10^4$ The wide hole has high Nusselt number compare to others. The rib has an open area ratio of 20% is optimum
8	Perforated blocks with five different shapes (Experimental analysis)	Shin and Kwak [19]	20000–40000	7,5	1	-	0°	-	-
9	Perforated baffles (Experimental analysis)	Karwa et al. [22]	2850–11500	7,77	0,0495	P=550 mm	0°	-	Baffles with 46,8% area ratio have the best performance compared to the smooth duct at equal pumping power.
10	Half and fully perforated baffles (Experimental analysis)	Karwa and Maheswari [23]	2700–1150	7,77	0,0495	P=137,274 -0,047	0°	$Nu=0,0893Re^{0,78608}$ (Deviation: ±1,34%) $f=0,1673Re^{-0,0213}$ (Deviation: ±3,34%) for half perforated baffles with 26% open area ratio approximately	Half perforated baffles with 26% open area ratio have 51,6% - 75% over smooth duct equal pumping power related to pressure loss.

Table 3. Summary of crucial features of winglet turbulators used by various investigators

No	Arrangement and (Analysis method)	Investigators	Reynolds Number (Re)	Angle of attack (°)	Relative height ( $\epsilon/D_h$ )	Relative roughness pitch ( $p/\epsilon$ )	Other parameters	Derived Correlations	Remarks
11	Spherical turbulence generators (Numerical and Experimental analysis)	Manjunath M.S. et al [24]	4000–25000	0°	1	3, 6 and 12	-	-	The best heat transfer performance is found out when $D=25$ mm and $p/\epsilon=3$ at $Re=2.3560$ . The performance is higher about 2.5 times than the base scenario.
12	Crossflow heat exchanger with V-type winglets (Experimental analysis)	Kotcioglu I. et al. [25]	$m=11-23$ kg/s	30°	-	-	height of the ducts	-	Entropy generation is controlled by the angle of the winglets and velocity of the fluid.
13	In a rectangular channel with a longitudinal vortex generator (Numerical analysis)	Wu and Tao [26]	800–3000	15°, 30°, 45°, 60°	-	-	punched wall surface area	-	45° is the best angle to have higher heat transfer performance, but the pressure drop down is increased about 2.3 times
14	Trapezoidal winglet type vortex generators (Experimental analysis)	Zhou and Ye [27]	700–26800	0° and 90°	0.5	-	Length of vortex generator (a)=40,width of vortex generator	-	Smaller attack angle, larger curvature and larger inclination gives the better thermohydraulic performance
15	Rib with delta winglet (Experimental analysis)	Promvongse et al. [29]	5000 – 22000	30° and 60°	0.5	1.3	Delta winglet arrangement(a) Pointing upstream(b) Pointing downstream	-	Heat transfer augmentation $Nu_s=2.3-2.6$ Pressure drop ratio $f/f_s=4.7-10.1$
16	Longitudinal vortex generators as delta and rectangular winglets (Numerical and Experimental analysis)	Wu and Tao [30]	500–2000	15°, 30°, 45°, 60°	-	-	the height of winglets	-	60° angled delta winglet has the highest heat transfer performance
17	Fin and oval tube exchanger with delta winglets (Numerical analysis)	Chu et al. [31]	500–2500	15°, 30°, 45°, 60°	Row numbers 2,3,4 and 5	-	the height of winglets, elliptical pipes, angle of fins and row number	-	While the heat transfer performance is increased by about 13.6–32.9% the friction factor is increased 29.2–40.6% with the best scenario

## NOMENCLATURE

$Re$	Reynolds Number $[=UD_h/\nu]$
$Nu$	Nusselt Number $[=hD_h/k]$
$f$	Friction Factor
$e$	Groove depth (mm)
$H$	Height (mm)
$p$	Pitch (mm)
$AR$	Duct aspect ratio $[=W/H]$
$HVAC$	Heating Ventilation and Air Conditioning
$TEF$	Thermal efficiency factor
$LVG$	Longitudinal vortex generators
$WPT$	Staggered-winglet perforated tapes
$WTT$	Staggered-winglet typical non-perforated tape
$D$	Diameter (mm)
$D_h$	Hydraulic diameter (m)
$W$	Width (mm)
$DW$	Delta winglet
$P-EW$	Punched elliptical winglet
$P-DW$	Punched delta winglet
$\beta$	Perforation angle ( $^\circ$ )
$\eta$	Thermal performance enhancement factor
$MWCNT$	Multi walled carbon nanotubes

## AUTHORSHIP CONTRIBUTIONS

Authors equally contributed to this work.

## DATA AVAILABILITY STATEMENT

The authors confirm that the data that supports the findings of this study are available within the article. Raw data that support the finding of this study are available from the corresponding author, upon reasonable request.

## CONFLICT OF INTEREST

The author declared no potential conflicts of interest with respect to the research, authorship, and/or publication of this article.

## ETHICS

There are no ethical issues with the publication of this manuscript.

## REFERENCES

- [1] Wang C, Lo J, Lin Y, Liu M. Flow visualization of wave-type vortex generators having inline fin-tube arrangement. *Int J Heat Mass Transf* 2002;45:1933–1944. [\[CrossRef\]](#)
- [2] Depaiwa N, Chompookham T, Promvong P. Thermal enhancement in a solar air heater channel using rectangular winglet vortex generators. *International Conference on Energy and Sustainable Development*; 2010. p.1–7. [\[CrossRef\]](#)
- [3] Alam T, Saini RP, Saini JS. Heat and flow characteristics of air heater ducts provided with turbulators-A review. *Renew Sust Energ Rev* 2014;31:289–304. [\[CrossRef\]](#)
- [4] Liou TM, Chang SW, Chan SP. Experimental study on thermal flow characteristics in square serpentine heat exchangers mounted with louver-type turbulators. *Int J Heat Mass Transf* 2018;15:897–908. [\[CrossRef\]](#)
- [5] Promvong P, Skullong S. Heat transfer in solar receiver heat exchanger with combined punched-V-ribs and chamfer-V-grooves. *Int J Heat Mass Transfer* 2019;143:118486. [\[CrossRef\]](#)
- [6] Han JC, Park JS. Developing heat transfer in rectangular channels with rib turbulators. *Int J Heat Mass Transfer* 1988;31:183–195. [\[CrossRef\]](#)
- [7] Han J. Heat transfer and friction characteristics in rectangular channels with rib turbulators. *ASME Journal Heat Transfer* 1988;110:321–328. [\[CrossRef\]](#)
- [8] Zhang JF, Joshi YK, Tao WQ. Single-phase laminar flow and heat transfer characteristics of micro gaps with longitudinal vortex generator array. *Int J Heat Mass Transf* 2017;111:484–494. [\[CrossRef\]](#)
- [9] Lau SC, Kukreja RT, Mcmillin RD. Effects of V-shaped rib arrays on turbulent heat transfer and friction of fully developed flow in a square channel. *Int J Heat Mass Transfer* 1991;34:1605–16. [\[CrossRef\]](#)
- [10] Wang L, Sundén B. Experimental investigation of local heat transfer in a square duct with various-shaped ribs. *Heat Mass Transfer* 2006;43:759–766. [\[CrossRef\]](#)
- [11] Han JC, Zhang YM. High-performance heat transfer ducts with parallel broken and V-shaped broken ribs. *Int J Heat Mass Transf* 1992;35:513–523. [\[CrossRef\]](#)
- [12] Promvong P, Thianpong C. Thermal performance assessment of turbulent channel flows over different shaped ribs. *Int Commun Heat Mass Transf* 2008;35:1327–1334. [\[CrossRef\]](#)
- [13] Li X, Xie G, Liu J, Sundén B. Parametric study on flow characteristics and heat transfer in rectangular channels with strip slits in ribs on one wall. *Int J Heat Mass Transf* 2020;149:118396. [\[CrossRef\]](#)
- [14] Salhi JE, Amghar K, Bouali H, Salhi N. Combined heat and mass transfer of fluid flowing through horizontal channel by turbulent forced convection. *Model Simul Eng* 2020;1453893:1–11. [\[CrossRef\]](#)
- [15] Sara ON, Pekdemir T, Yapici S, Yilmaz M. Heat transfer enhancement in a channel flow with perforated rectangular blocks. *Int J Heat Fluid Flow* 2001;22:509–518. [\[CrossRef\]](#)
- [16] Hwang JJ, Liou TM. Heat transfer in a rectangular channel with perforated turbulence promoters using holographic interferometry measurement. *Int J Heat Mass Transfer* 1995;38:3197–207. [\[CrossRef\]](#)

- [17] Moon SW, Lau SC. Heat transfer between blockages with holes in a rectangular channel. *J Heat Transfer* 2003;125:587. [\[CrossRef\]](#)
- [18] Buchlin J. Convective heat transfer in a channel with perforated ribs *Transfer de chaleur par convection dans un canal muni de pontets perforés*. *Int J Therm Sci* 2002;41:332–340. [\[CrossRef\]](#)
- [19] Shin S, Kwak JS. Effect of hole shape on the heat transfer in a rectangular duct with perforated blockage walls. *J Mech Sci Technol* 2008;22:1945–1951. [\[CrossRef\]](#)
- [20] Zheng N, Yan F, Zhang K, Zhou T, Sun Z. A review single-phase convective heat transfer enhancement based on multi-longitudinal vortices in heat exchanger tubes. *Appl Therm Eng* 2020;164:1–23. [\[CrossRef\]](#)
- [21] Skullong S, Promvong P, Thianpong C, Pimsarn M. Heat transfer and turbulent flow friction in a round tube with staggered-winglet perforated-tapes. *Int J Heat Mass Transfer* 2016;95:230–242. [\[CrossRef\]](#)
- [22] Karwa R, Maheshwari BK, Karwa N. Experimental study of heat transfer enhancement in an asymmetrically heated rectangular duct with perforated baffles. *Int Commun Heat Mass Transfer* 2005;32:275–284. [\[CrossRef\]](#)
- [23] Karwa R, Maheshwari BK. Heat transfer and friction in an asymmetrically heated rectangular duct with half and fully perforated baffles at different pitches. *Int Commun Heat Mass Transfer* 2009;36:264–8. [\[CrossRef\]](#)
- [24] Manjunath MS, Karanth KV, Sharma NY. Numerical analysis of the influence of spherical turbulence generators on heat transfer enhancement of flat plate solar air heater. *Energy* 2017;121:616–630. [\[CrossRef\]](#)
- [25] Kotcioglu I, Caliskan S, Cansiz A, Baskaya S. Second law analysis and heat transfer in a cross-flow heat exchanger with a new winglet-type vortex generator. *Energy* 2010;35:3686–3695. [\[CrossRef\]](#)
- [26] Wu JM, Tao WQ. Numerical study on laminar convection heat transfer in a rectangular channel with longitudinal vortex generator. Part A: verification of field synergy principle. *Int J Heat Mass Transf* 2008;51:1179–1191. [\[CrossRef\]](#)
- [27] Zhou G, Ye Q. Experimental investigations of thermal and flow characteristics of curved trapezoidal winglet type vortex generators. *Appl Therm Eng* 2012;37:241–248. [\[CrossRef\]](#)
- [28] Gentry MC, Jacobi AM. Heat transfer enhancement by delta-wing vortex generators on a flat plate: vortex interaction with the boundary layer. *Exp Therm Fluid Sci* 1997;14:231–242. [\[CrossRef\]](#)
- [29] Promvong P, Khanoknainyaakarn C, Kwankaomeng S, Thianpong C. Thermal behaviour in solar air heater channel fitted with combined rib and delta-winglet. *Int Commun Heat Mass Transf* 2011;38:749–756.
- [30] Wu JM, Tao WQ. Effect of longitudinal vortex generator on heat transfer in rectangular channels. *Applied Thermal Engineering* 2012;37:67–72. [\[CrossRef\]](#)
- [31] Chu P, He YL, Lei YG, Tian LT, Li R. Three-dimensional numerical study on fin-and-oval-tube heat exchanger with longitudinal vortex generators. *Appl Therm Eng* 2009;29:859–876. [\[CrossRef\]](#)
- [32] Promvong P, Skullong S. Enhanced Heat Transfer in Rectangular Duct with Punched Winglets, *Chinese J Chem Eng* 2020;28:660–71. [\[CrossRef\]](#)
- [33] Sarafraz MM, Safaei MR, Goodarzi M, Yang B, Arjomandi M. Heat transfer analysis of Ga-In-Sn in a compact heat exchanger equipped with straight micro-passages. *Int J Heat Mass Transf* 2019;139:675–684. [\[CrossRef\]](#)
- [34] Goodarzi M, Kherbeet AS, Afrand M, Sadeghinezhad E, Mehrli M, Zahedi P, et al. Investigation of heat transfer performance and friction factor of a counter-flow double-pipe heat exchanger using nitrogen-doped, graphene-based nanofluids. *Int Commun Heat Mass Transfer* 2016;76:16–23. [\[CrossRef\]](#)
- [35] Goodarzi M, Amiri A, Goodarzi MS, Safae M, Karimipour A, Languri EM, Dahari M. Investigation of heat transfer and pressure drop of a counter flow corrugated plate heat exchanger using MWCNT based nanofluids. *Int Commun Heat Mass Transfer* 2015;66:172–179. [\[CrossRef\]](#)
- [36] Sarafraz MM, Safaei MR, Tian Z, Goodarzi M, Bandarra EP, Arjomandi M. Thermal assessment of nano-particulate graphene-water/ethylene glycol (w/w 60:40) nano-suspension in a compact heat exchanger. *Energies* 2019;12:1929. [\[CrossRef\]](#)
- [37] Alam T, Saini RP, Saini JS. Heat and flow characteristics of air heater ducts provided with turbulators – A review. *Renew Sust Energy Rev* 2014;31:289–304. [\[CrossRef\]](#)
- [38] Awais M, Bhuiyan A. Heat transfer enhancement using different types of vortex generators A review on experimental and numerical activities. *Therm Sci Eng Prog* 2018;5:524–545. [\[CrossRef\]](#)
- [39] Alam T, Saini RP, Saini JS. Use of turbulators for heat transfer augmentation in an air duct - a review. *Renew Energy* 2014;62:689–715. [\[CrossRef\]](#)
- [40] Torii K, Yanagihara JL. The effects of longitudinal vortices on heat transfer of laminar boundary layers. *JSME Int J* 1989;32:395–402. [\[CrossRef\]](#)
- [41] Joardar A, Jacobi A. Impact of leading edge delta-wing vortex generators on the thermal performance of a flat tube, louvered-fin compact heat exchanger. *Int J Heat Mass Transfer* 2005;48:1480–1493. [\[CrossRef\]](#)
- [42] Prasopsuk C, Hoonpong P, Skullong S, Promvong P. Experimental investigation of thermal performance enhancement in tubular heat exchanger fitted with

- rectangular-winglet-tape vortex generator, *KKU Engineering Journal* 2016;43:279–282. [\[CrossRef\]](#)
- [43] Hiravennavar SR, Tulapurkara EG, Biswas G. A note on the flow and heat transfer enhancement in a channel with built-in winglet pair. *Int J Heat Fluid Flow* 2007;28:299–305. [\[CrossRef\]](#)
- [44] Gong B, Wang LB, Lin ZM. Heat transfer characteristics of a circular tube bank fin heat exchanger with fins punched curve rectangular vortex generators in the wake regions of the tubes. *Appl Therm Eng* 2015;75:224–238. [\[CrossRef\]](#)
- [45] Ke F, Wang LB, Hua L, Gao SD, Su YX. The optimum angle of attack of delta winglet vortex generators on heat transfer performance of finned flat tube bank with considering non-uniform fin temperature. *Exp Heat Transf* 2006;19:227–249. [\[CrossRef\]](#)
- [46] Tiwari S, Maurya D, Biswas G, Eswaran V. Heat transfer enhancement in cross-flow heat exchangers using oval tubes and multiple delta winglets. *Int J Heat Mass Trans* 2003;46:2841–2856. [\[CrossRef\]](#)