

This paper was recommended for publication in revised form by Regional Editor Omid Mahian

ANALYSIS OF CONTROL STRATEGIES AND SIMULATION OF HEATING SYSTEMS USING SIMULINK/MATLAB POTENTIAL

***A. Saleh**

Department of Mechanical Engineering
Faculty of Engineering, Aljouf University
Sakaka, Aljouf, Saudi Arabia

M. Mosa

Department of Mechanical Engineering
Faculty of Engineering, Aljouf University
Sakaka, Aljouf, Saudi Arabia

Keywords: Thermal Control; Dynamic Modeling; On-Off Controller; PID Controller; Simulink/Matlab

** Corresponding author: A. Saleh, Phone: 00966 562345153*

E-mail address: asaleha@ju.edu.sa

ABSTRACT

In this work the Simulink/Matlab potential is used to develop a dynamic model of a forced air type heating system. The main concern was centered on the analysis of control strategies to improve the system performance and to investigate the effect of thermal parameters on system performance and energy efficiency. A comparative analysis of On-Off and PID control strategies was conducted to investigate the features of each in terms of comfort and power consumption. The effects of thermal parameters such as thermal capacity, equivalent thermal resistance and set point setting were investigated. The results showed that Simulink/Matlab has a very high potential to analyze control strategies and to investigate thermal characteristics. Although the On-Off strategy is recommended for its constructive simplicity, lower cost and energy saving capability, the results showed to be oscillatory, inaccurate and instable. On the other hand, it was found that PID strategy performs better in terms of overshoot, settling time reduction and in suppressing the effect of external temperature disturbances. The overshoot was around 4 % and the steady state error disappeared quickly. Simulation results showed that high thermal mass buildings can significantly reduce the room air temperature variation; lower set point setting reduced the cumulative energy consumed and an increase in the equivalent thermal resistance led to a significant saving in energy consumption.

INTRODUCTION

There is a wide variety of software packages that could offer the possibility to model the components of thermodynamic systems; Simulink/Matlab is one of the most effective softwares that have advanced features for this purpose. Control of indoor temperature is one of the major issues in control of indoor conditions. This is due to the severe and frequent changes in the outdoor conditions. Another important issue is having energy efficient systems. Often these two factors are incompatible and a preference between them must be made.

Several years ago, many researchers developed dynamic models for HVAC systems by using Matlab/Simulink environment. Hudson and Underwood [1] presented a mathematical model for building simulation. The model is considered adequate for high mass buildings having represented the building by an RC electric circuit that is predominantly capacitive. Mendes et al. [2] used a lumped capacitance approach to model the room air temperature and a multi-layer model for the building envelope. The model presented allows studying the transient analysis of indoor temperature when external air temperature has sinusoidal variation. Riederer et al. [3] presented a detailed list of criteria used in the development of the zone models. They also studied the influence of the sensor position in the control process. Tashtoush et al. [4] modeled and analyzed the heating and cooling system separately by using PID controllers. They investigated the simulation results for both open loop and closed loop systems. Peng et al. [5] developed a state space model for an air conditioning system consisting of two blocks connected in

series with negative feedback and reached a satisfactory results related to response for the indoor conditions.

On-Off control strategy is the simplest control system with only two states, On and Off, and is specific to the systems that are able to operate only at full power. PID control strategy is common for advanced thermal and heating systems. Breemen and De Vries [6] conducted a comparative analysis of the On-Off, PID and MPC controllers and proposed, as a good strategy, to use a hybrid solution as a combination of individual and independent controllers each one to act in predefined temperature range for complex control systems. Mendes et al. [7] presented an analysis of an On-Off controller and described other control strategies like Fuzzy-Logic, Robust, Intelligent, Adaptive and Predictive. They investigated their utility of use in complex HVAC systems. Van Schijndel et al. [8] analyzed a complex solar heat pump system by using combined strategies of control, where they used PID strategy for temperature control and On-Off strategy for humidity control. They compared the Simulink results with measured results and obtained a good correspondence. Novak et al. [9] presented a model in terms of non-linear state-space equations. Two control loop structures were described and analyzed. The IMC structure is used for the PID controller tuning procedure. They presented results of simulation in terms of indoor temperature, relative humidity, and energy consumption. Paracu et al. [10] developed a comparative analysis of On-Off and PI control strategies for heating a building. They showed that for both controllers when are set with the optimum parameters for functioning, the difference in energy consumption is insignificant, instead still exist a difference in the resulted thermal comfort.

This study used the potential of Simulink environment to develop a dynamic model of a forced air heating system and aims to find the evolution of the response of the system by using two control strategies, On-Off and PID, in order to identify the features of each type. It was also conducted an investigation of the effect of many parameters on the inside comfortable conditions and the efficiency of energy consumption.

MODEL DESCRIPTION

The system considered includes many subsystems such as outdoor environment, thermal characteristics of the house, heating coil and control system. During operation, cold air enters the heater to be heated and sent to the conditioned space. The simulation run was made by both On-Off and PID control strategies. In case of On-Off strategy control, the thermostat senses the difference between the indoor temperature and the set point and sends a signal to the thermostat which switches the heater on and off and limits the fluctuation around the set point. In case of PID algorithm, the controller uses the error signal to modulate the actuator used to modify the output of the heater.

On-Off controllers have the advantage of simplicity and a switching function that can be scheduled. The fluctuation limits for commercial buildings can be set depending on heating system. A drawback is that exist only two states that determines the operation of full power or shutdown. The PID controller

forms the basis for many advanced control algorithms and is very common in HVAC systems.

The input data include the house geometry, the thermal properties of house materials, heater characteristics, the outdoor and indoor conditions and the initial conditions. The geometric and thermal characteristics are used to evaluate the equivalent thermal resistance of the house. The heater provides hot air to the space with a specified temperature and flow rate in case of On-Off controller. The energy provided to the heated space is integrated to give the accumulative consumption of energy. A typical schematic of the system is shown in Figure 1. The analysis is conducted when the heating coil is operating only. The heat flow is controlled by controlling the fan speed.

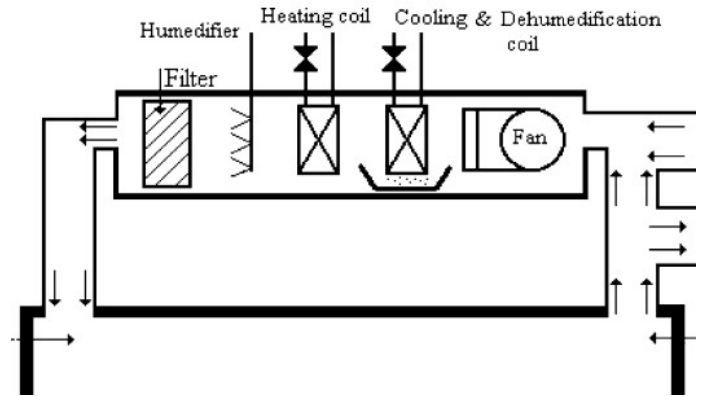

Figure 1 A typical schematic of the system

MATHEMATICAL MODELLING

To formulate the problem, many assumptions were made. The zone temperature is assumed to be uniform such that the lumped capacitance approach can be applied. The air density and specific heat are assumed to be constants. The pressure loss is considered to be negligible. Under these assumptions the heat flow rate supplied to the house is given by:

$$\frac{dQ_s}{dt} = \dot{m}c_p(T_h - T_{in}) \tag{1}$$

The heat lost from the room is expressed by:

$$\frac{dQ_l}{dt} = \frac{1}{R_{eq}}(T_{in} - T_o) \tag{2}$$

Applying energy balance equation to the house, the rate of change of the room temperature is given by:

$$\frac{dT_{in}}{dt} = \frac{1}{mc_p} \left(\frac{dQ_s}{dt} - \frac{dQ_l}{dt} \right) \tag{3}$$

where *m* is the mass of air inside the room.

Substituting equations (1) and (2) in equation (3), the equation becomes:

$$\frac{dT_{in}}{dt} = \frac{I}{mc_p} \left(\dot{m}c_p(T_h - T_{in}) - \frac{I}{R_{eq}}(T_{in} - T_o) \right) \quad (4)$$

Applying Laplace Transform and manipulating, equation (4) becomes:

$$T_{in}(s) = \frac{I}{s mc_p} \left[\dot{m}c_p(T_h(s) - T_{in}(s)) - \frac{I}{R_{eq}}(T_{in}(s) - T_o(s)) \right] \quad (5)$$

This equation shows the variables and parameters that affect the indoor temperature. The variables are the difference between hot air temperature and indoor temperature and the difference between indoor temperature and outdoor temperature. The parameters include the house volume

expressed in terms of the mass of air, the thermal properties of house materials expressed in terms of equivalent thermal resistance and the heater characteristics expressed in terms of mass flow rate and the temperature of hot air supplied to the house. The outdoor temperature is modeled by a sine wave function with a specified average and amplitude values to simulate the daily fluctuations.

Based on that, the model expressed by equation (5) is used to build the basic Simulink model used to investigate the control strategies and to investigate the effect of the various parameters. To assist in the analysis performed, the Simulink model was divided into five groups (subsystems), the Outdoor temperature model, the Thermostat model, the Heater model, the House model and the Output display model. By combining the various subsystems, the overall model appears as shown in Figure 1.

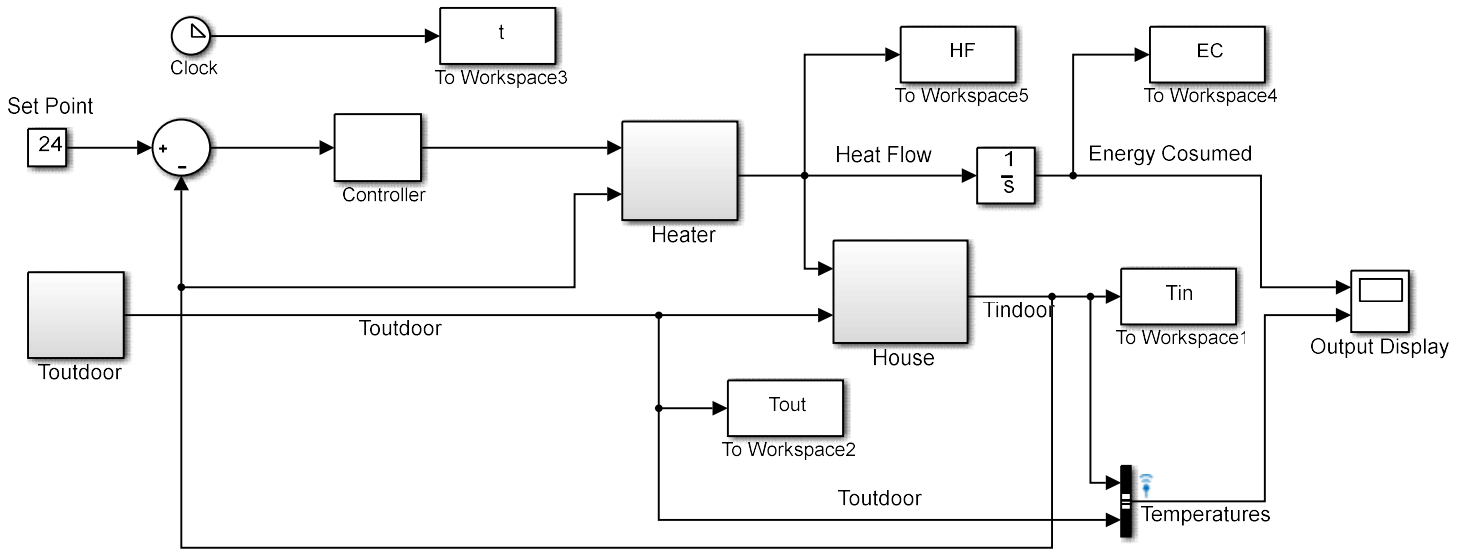

Figure 2 Simulink model of the proposed system

To show how the two control strategies are implemented with the model represented by equation (5) the detailed simulink models of the heater and the house are given in Figure 2.

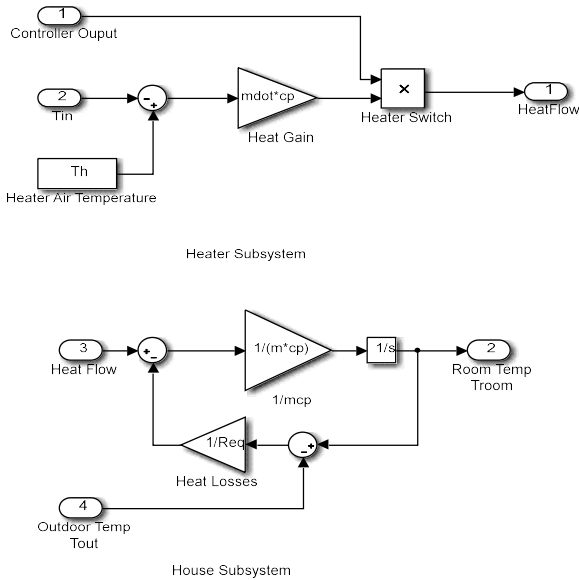

Figure 3 Simulink models of the heater and house subsystems

RESULTS AND DISCUSSION

The simulation was run with both control strategies, On-Off and PID controllers. The PID controller equation is defined by the signal $u(t)$ sent by the controller to the plant:

$$u(t) = k_p e(t) + k_i \int e(t)dt + k_d \frac{de(t)}{dt} \tag{6}$$

Where k_p , k_i and k_d are the proportional, integral and derivative gains respectively. The variable $e(t)$ represents the tracking error, the difference between the desired input value (Set Point) and the actual indoor temperature.

An essential step linked to the optimal functioning of the PID controller is tuning its internal parameters to meet the design specifications of the system. After being tuned, the gains assumed the values, the proportional gain $k_p = 0.204$, the integral gain $k_i = 3.23$ and the derivative gain $k_d = -0.0045$. The simulation run time was chosen for 2 cycles or 48 hours. Generally, when a system is exposed to external cyclic variation then it is recommended that the simulation time to be more than one cycle until the components of the system are stabilized.

Initially the indoor temperature was fixed to be 20°C and the set point was fixed at 24°C. Changes in outdoor temperature are simulated by a sine wave function with amplitude of 8 degrees and a base temperature of 10 degrees. The thermostat was set to limit the fluctuation 3 °C around the set point. By running the simulation, the system performance can be investigated in function of different variables and parameters.

Effect of the control strategy on indoor temperature

The indoor temperature resulted in both control strategies, On-Off and PID, is shown in Figure 2. In case of PID algorithm, the response tracked efficiently the set point with zero steady state error and the outdoor disturbances were rejected. The indoor temperature peaks to about 25°C, which means an overshoot around 4%. In terms of comfort, the human body is usually insensitive to temperature variations of less than 5% for short periods [11]. This means that at a temperature of 24°C, a variation of about 1 degree Celsius will not influence significantly the state of comfort.

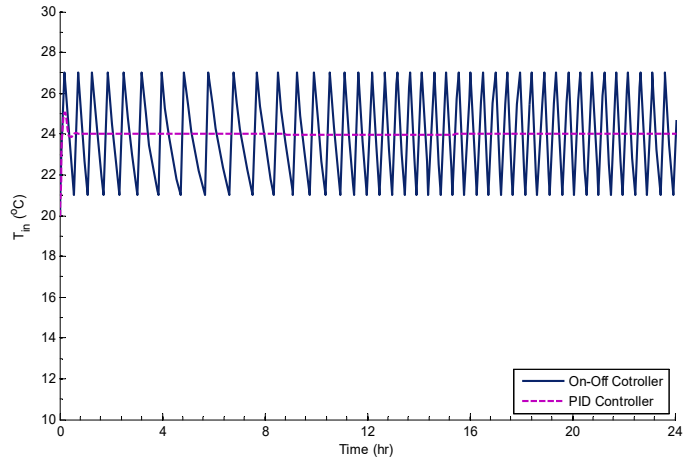

Figure 4 Effects of on-off and pid control strategies on indoor temperature

On the other hand, the fluctuation of the indoor temperature with On-Off controller is 3 degree centigrade, a variation that will influence significantly the state of comfort. Someone may think to reduce the fluctuation limit to 1 degree C. Comparing the two limits of fluctuation as shown in Figure 3, it can be noticed that the frequency of oscillation has been increased significantly. Clearly, this will increase the device mechanical wear and reduce the level of reliability.

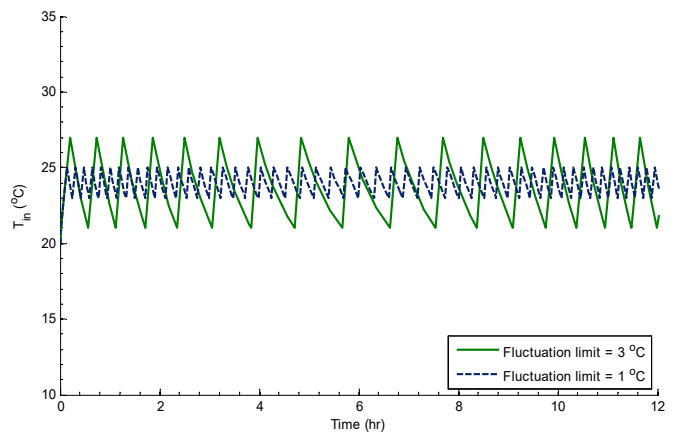

Figure 5 Effect of changing the fluctuation limits of on-off controller

Effect of thermal capacity

Effect of thermal capacity, $C = c_p m$, on indoor temperature is investigated for both controllers. In this case the mass will include, in addition to the mass of air, the mass of other possible things inside the room. The results in case On-Off controller are shown in Figure 4. As thermal capacity is increased 10 times the reference adopted value, $C_{ref} = 1778.4 \text{ kJ/C}$, a significant decrease in the frequency of the fluctuation followed. The opposite happened if the value was reduced to one tenth of the reference value. From this it can be concluded that the On-Off controller will work in better circumstances with systems having high thermal capacity.

Effect of thermal capacity on the indoor temperature in case of PID controller is shown in Figure 5. It can be noticed that at higher thermal capacity both overshoot percentage and settling time increased. This can be explained remembering that high thermal capacity systems need more time to feel the changes in temperature.

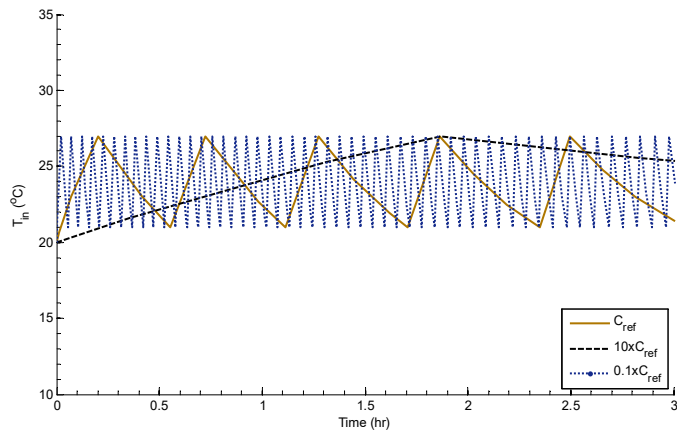

Figure 6 Effect of thermal capacity on the indoor temperature in case of on-off controller

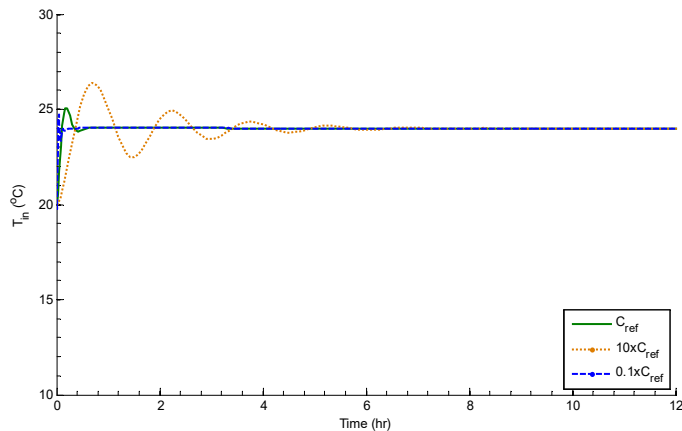

Figure 7 Effect of thermal capacity on the indoor temperature in case of pid controller

Effect of mass flow rate on the indoor temperature

Effect of mass flow rate on the indoor temperature is shown in Figure 6.

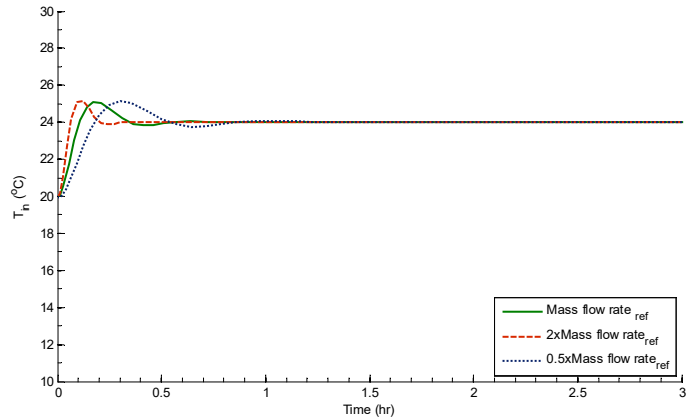

Figure 8 The effect of mass flow rate on the indoor temperature in case of pid controller

The reference value of mass flow rate adopted was 3600 kg/hr. It can be noticed that, as the mass flow rate is doubled, the rise time decreased and the system settled faster. The opposite occurred if the value is reduced to the half of the reference value. Although there is a small increase in the overshoot percentage with the mass flow rate, but this increase has no significant influence on the state of comfort. This means that an increase in the mass flow rate is desirable if there are no other factors that prevent this.

Effect of control strategy on energy consumption and heat flow

Figure 7 shows the cumulative energy consumption, EC , and heat flow, HF , supplied by the system for a 48-hr period. As can be seen, the difference in cumulative energy consumed is negligible between both control algorithms. With regard to heat flow, there is a difference between the control strategies. In case of On-Off controller the hot air is supplied intermittently while in case of PID controller there is a continuous supply. This will impact significantly the air distribution system and therefore the state of comfort will be superior in case of PID controller.

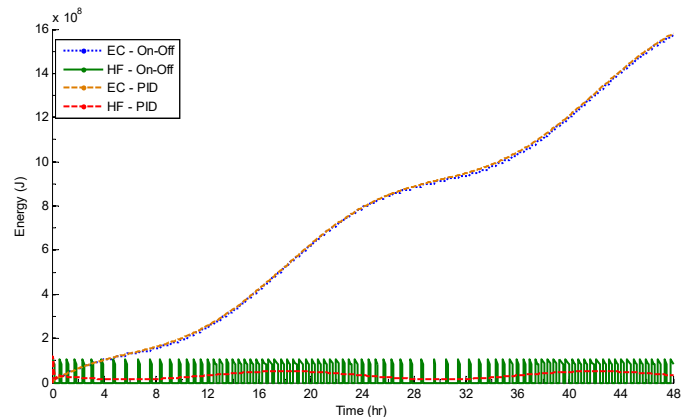

Figure 9 Effect of control strategy on energy consumption and heat flow rate

Effect of equivalent thermal resistance

The equivalent thermal resistance of the heated space considered includes the thermal and geometric characteristics of the walls and windows. Its effect on the energy consumed is shown in Figure 8.

The reference value adopted, $Re_{eq,ref}$, was $0.0015 \text{ m}^2\cdot\text{C}/\text{W}$, at which the energy consumed was 1581 MJ after 48 hours. As expected, as equivalent thermal resistance is doubled the energy consumed is reduced almost to the half, 794 MJ. The opposite happens if the value is reduced to the half, the energy consumed almost doubled to the value 3154 MJ. This, obviously, reflects the important of selecting low thermal conductivity materials and effective insulation techniques.

Effect of Thermostat Setting

The thermostat setting was changed by considering three different values; 22, 24 and 26 °C. Its effect on the energy consumed is shown in Figure 9.

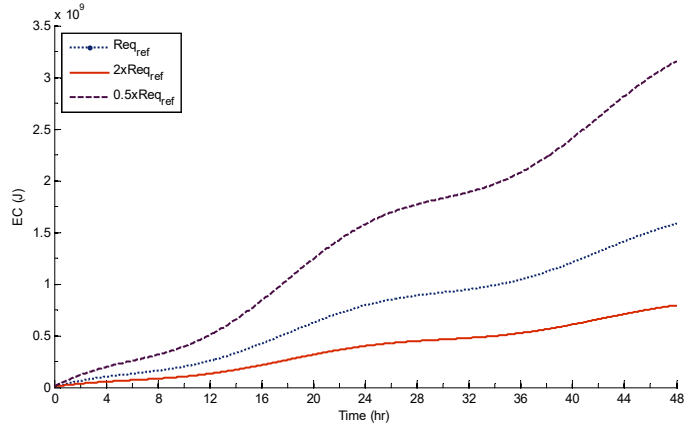

Figure 10 Effect of equivalent thermal resistance on energy consumption

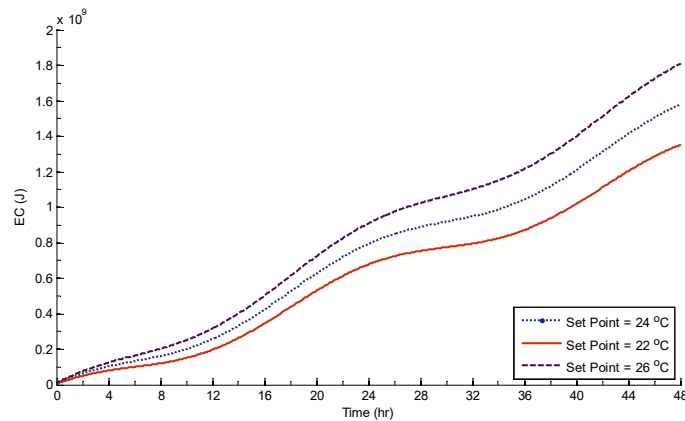

Figure 11 Effect of set point value on energy consumption

As expected, an increase in set point value led to an increase in the energy consumed. From the figure it can be noticed that an increase of 2 degrees in the set point was accompanied by about 15% increase in the energy consumed. Of course, this difference is significant if we take into account the extension of the actual operating periods which makes the

reduction in set point value an important task to be considered wherever and whenever possible.

Effect of the temperature of hot air supplied to the space

The effect of the temperature of the hot air supplied to the space on energy consumption is shown in Figure 10. The adopted value of the temperature of the hot water supplied is 50 °C. It can be noticed that a decrease in this value from 50 to 40 °C has insignificant effect on the overshoot percentage, but the response became slower. The opposite occurred when the hot air temperature increased from 50 to 60 °C. Based on this, it can be said that it is desirable to increase the temperature of air supplied if there are no other obstacles.

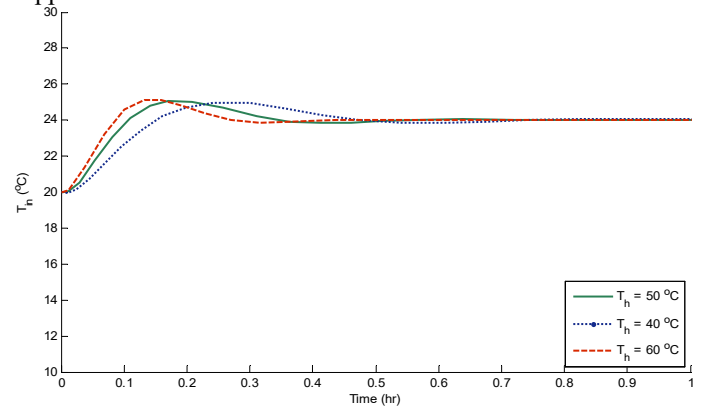

Figure 12 Effect of temperature of hot air supplied on the indoor temperature

CONCLUSION

In this work a forced air type heating system model was develop using Simulink/Matlab potential. A comparative analysis was conducted between two strategies of control, On-Off and PID. The model developed was used to investigate the effect of many parameters on system performance and energy efficiency. Based on the work described here, it is possible to make the following conclusions:

- The results obtained showed that the PID controller is capable of tracking the set point effectively and rejecting outdoor disturbances.
- In case of PID algorithm the indoor temperature peaks to about 25°C, equivalent to an overshoot around 4%; a value that has insignificant effect on the state of comfort.
- The fluctuation caused by On-Off controller influences significantly the state of comfort. If the fluctuation limit was reduced, an increased frequency of oscillation resulted that affects the state of comfort and the reliability of the device.
- An increase in thermal capacity of the system controlled by On-Off algorithm led to a significant decrease in the frequency of the fluctuation.
- An increase in thermal capacity of the system controlled by PID algorithm led to an increase in overshoot percentage and settling time.
- For systems controlled by PID algorithm, an increase in mass flow rate and in the temperature of hot air supplied, affected

positively the settling time and they had a negligible negative effect on the overshoot percentage.

- It was found that there is no difference in the energy consumed between the two controllers, but the state of comfort is significantly improved in the case of PID controller.
- Both the equivalent thermal resistance and the set point value play an important role in reducing energy consumption with the major role played by the equivalent thermal resistance.

NOMENCLATURE

C	Thermal capacity, J/°C
c_p	Air specific heat, J/kg.°C
e	Tracking error, K
EC	Energy consumption, J
HF	Heat flow, J
m	Mass of air inside the room, kg
\dot{m}	Mass flow rate of air, kg/s
Q_l	Heat lost from the room, J
Q_s	Heat flow to the room, J
R_{eq}	Equivalent thermal resistance, m ² .°C/J/hr
t	Time, hr
T_h	Temperature of hot air, °C
T_{in}	Room temperature, °C
T_o	Outdoor temperature, °C

REFERENCES

- [1] Hudson G., Underwood C. P. A simple building modeling procedure for Matlab/Simulink, Proceedings of the 6th International Conference on Building Performance Simulation (IBPSA'99), September 1999, Kyoto-Japan, pp. 777-783.
- [2] Mendes N., Oliveira G. H. C., De Araújo H. X. Building thermal performance analysis by using matlab/simulink, Proc. of the Building Simulation Conference (IBPSA'01), Vol. 1, 2001, Rio de Janeiro, Brazil, pp. 473-480.
- [3] Riederer P, Marchio D, Visier JC, Husaunndee A, Lahrech R. Energy Building Trans 2002;37:777–90.
- [4] Tashtoush B., Molhim M., Al-Rousan M. Dynamic model of an HVAC system for control analysis, Energy 30 (2005) 1729–1745.
- [5] Peng X., Paassen A. State space model for predicting and controlling the temperature response of indoor air zones, Energy Building Trans 1998; 28:197–203.
- [6] Breemen A.J.N. van, Vries T.J.A. de, Design and implementation of a room thermostat using an agent-based approach, Control Engineering Practice 9 (2001) 233-248, Pergamon, 2001.
- [7] Mendes N., Oliveira G.H.C, Araújo H.X., Coelho L.S. A Matlab-based simulation tool for building thermal performance analysis, 8th International IBPSA Conference, Eindhoven, Netherlands, August 11-14, 2003.
- [8] Schijndel A.W.M. van, Wit M.H. de, Advanced Simulation of Building Systems and control with Simulink, 8th International IBPSA Conference, Eindhoven, Netherlands, August 11-14, 2003.
- [9] Novak P.R., Mendes N., Oliveira G.H.C. Simulation of HVAC plants in 2 Brazilian cities using MATLAB/SIMULINK, Ninth International IBPSA Conference, Montreal, Canada, August 15-18, 2005.
- [10] Paracu T., Muresan M., Badea A. A comparative analysis of the controllers On-Off and PI for the heating system of a building, Proceedings of PLUMEE 2013, 26-32.
- [11] Oughton D.R., Hodkinso S. Heating and Air Conditioning of Buildings, 2002 9th edition, Butterworth-Heinemann, Oxford, 2002.